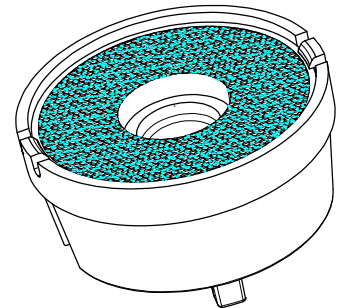
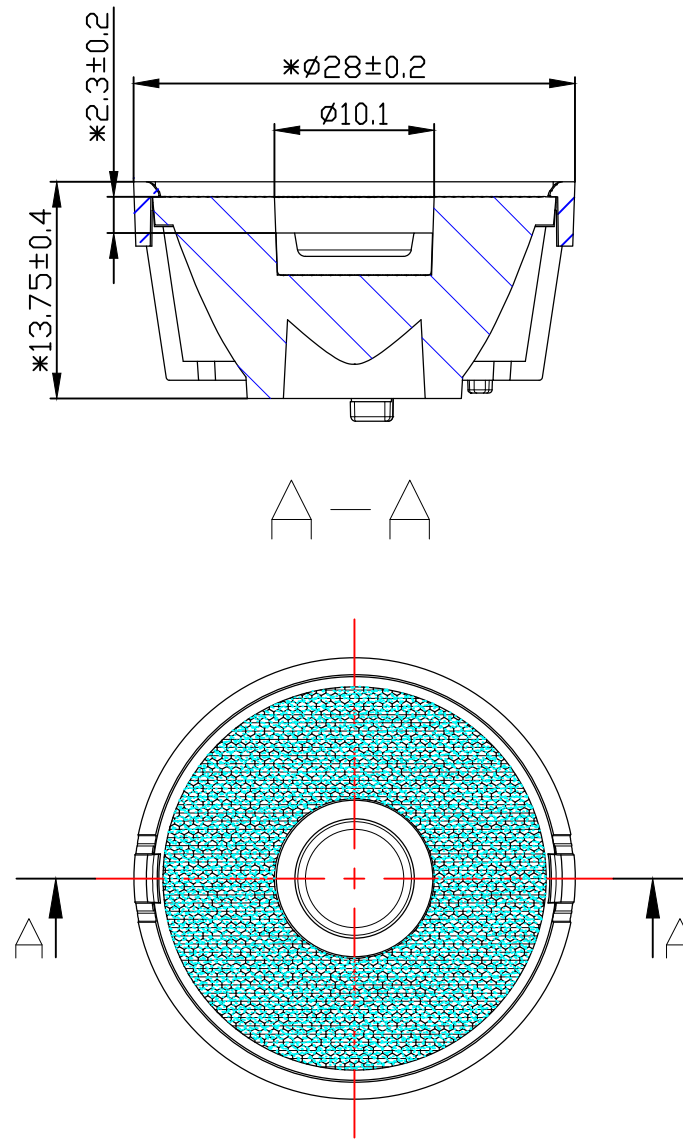

table for unmentioned tolerance in the drawing (unit: mm)				punch angle tolerance in the drawing (unit:degree)		
> 0-5	> 5-30	> 30-90	> 90-150	0-10	10-50	50-120
±0.15	±0.2	±0.4	±0.5	±1°	±0.5°	±0.3°
> 150-250	> 250-400	> 400-700		120-250	250-360	360 above
±0.8	±1.5	±2		±0.2°	±0.166°	±0.085°

“*” Marked for key control dimensions



Light Source	LUMINUS CXM-3
PlasticHolder	
Metal Adaptor	
Design Angle	36° ±3°
Measured Angle	34.9°
Efficiency	
光学装配示意图	

Technical requirements:
 1. Material :PMMA.
 2. Press 3D for product without fillet and die drawing Angle.
 3. Non dimensioned measures refer to GB/ t14486-2008 MT5 standard.

				P/N: 91. 61. 0139. 000		版本/REV KO
				产品名称 Product Name		LN01D02836DA-N
				客户代号 Customer Code		NT
				客户编号 Customer Item		
标记 Mark	处数 Amended Times	更改内容 Amended Content		签名 Signature	更改日期 Amended Date	方案图 Engineering drawings
设计 Designer		制图 Drawing by	比例 Proportion	1:1		
工艺 Technology		审核 Auditor	视角 View		图档路径 The path of file	
批准 Approval		日期 Date	页数 Page	共1页 第1页		
		2022. 1. 18				Nata®