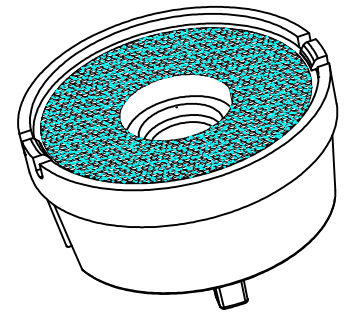
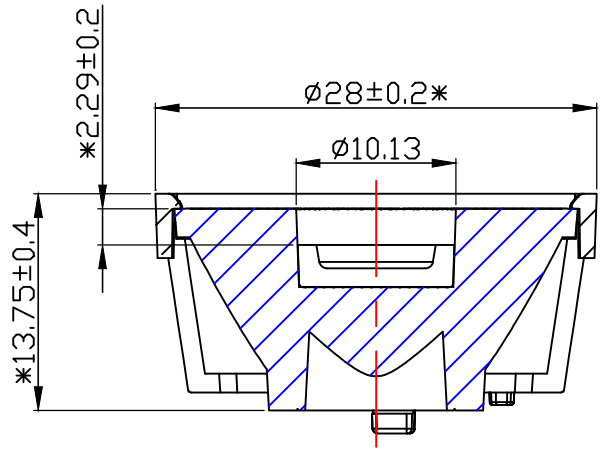
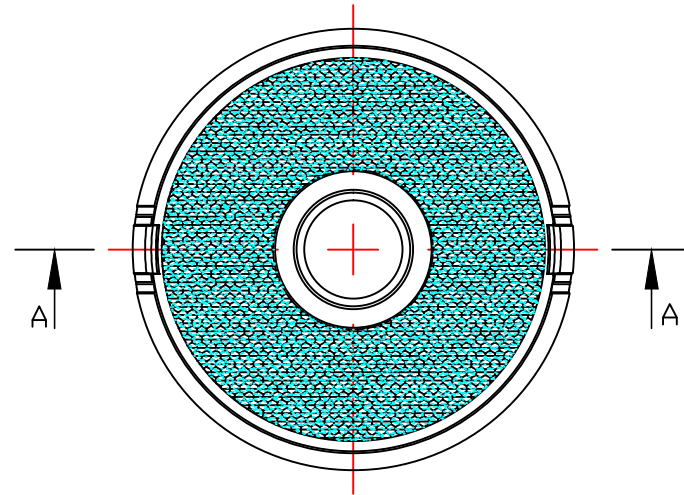

table for unmentioned tolerance in the drawing (unit: mm)				punch angle tolerance in the drawing (unit:degree)		
> 0-5	> 5-30	> 30-90	> 90-150	0-10	10-50	50-120
±0.15	±0.2	±0.4	±0.5	±1°	±0.5°	±0.3°
> 150-250	> 250-400	> 400-700		120-250	250-360	360 above
±0.8	±1.5	±2		±0.2°	±0.166°	±0.085°

“*” Marked for key control dimensions



A-A



Light Source	LUMINUS CXM-3
PlasticHolder	
Metal Adaptor	
Design Angle	17° ±3°
Measured Angle	17.9°
Efficiency	

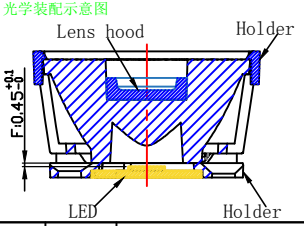

Technical requirements:
 1. Material :PMMA.
 2. Press 3D for product without fillet and die drawing Angle.
 3. Non dimensioned measures refer to GB/ t14486-2008 MT5 standard.

				P/N: 91. 61. 0135. 000		版本/REV KO
				产品名称 Product Name		LN01D02817DA-N
				客户代号 Customer Code		NT
				客户编号 Customer Item		
标记 Mark	处数 Amended Times	更改内容 Amended Content		签名 Signature	更改日期 Amended Date	方案图 Engineering drawings
设计 Designer		制图 Drawing by	比例 Proportion	视角 View	1:1	
工艺 Technology		审核 Auditor	日期 Date	图档路径 The path of file		
批准 Approval		日期 Date	2022. 1. 18	页数 Page	共1页 第1页	
						Nata®