

Product bill of material				
Serial number	material name	Masterial number	NO.	Describe
①	NA01AP透镜支架	97.70.104.00	1	Material:PC
②	CR01D01236AP	91.60.0021.000	1	Material:PMMA

table for unmentioned tolerance in the drawing (unit: mm)					
0-5	5-30	30-120	120-250	250-400	400-700
±0.15	±0.2	±0.5	±0.8	±1.5	±2

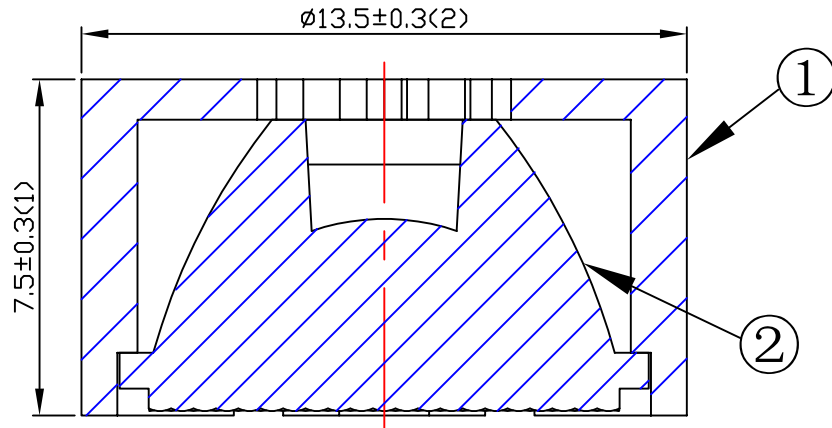

A - A

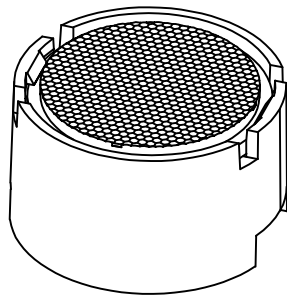
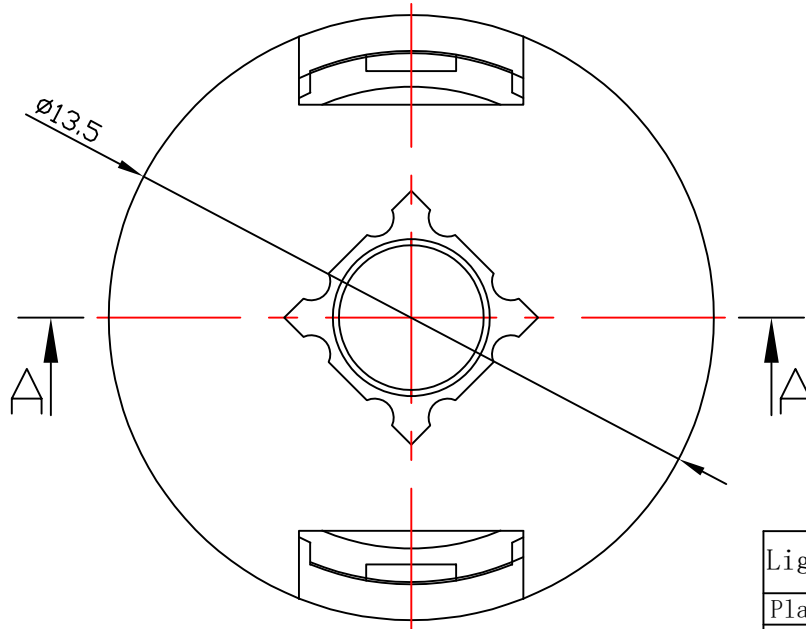

Light Source	CREE XP-E2
PlasticHolder	
Metal Adaptar	
Design Angle	$36^\circ \pm 3^\circ$
Measured Angle	36°
Efficiency	

光学装配视图

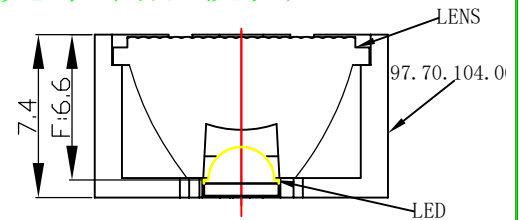

Mark	Amended Times	Amended Content	Signature	Amended Date	 Nata® NATA Lighting Co.,Ltd	
Controll Version	Design Version	Designer	Client Version	Proportion 1:1		
Technology	Auditor	View				
Approval	Date	2018. 10. 20	Page	Total Page		
						Customer Item
					Customer Code	NT
					Product Number	
					Product Name	CR01D01236AP-N