

Product bill of material				
Serial number	material name	Material number	NO.	Describe
①	8-0354-A	94.08.0354.000	1	Material:T=1.01070AL
②	6-0645-A	94.06.0645.000	1	Material:T=1.01070AL

table for unmentioned tolerance in the drawing (unit: mm)			punch angle tolerance in the drawing (unit:degree)		
0-5	5-30	30-120	0-10	10-50	50-120
±0.15	±0.2	±0.5	±1°	±0.5°	±0.3°
120-250	250-400	400-700	120-250	250-360	360 above
±0.8	±1.5	±2	±0.2°	±0.166°	±0.083°

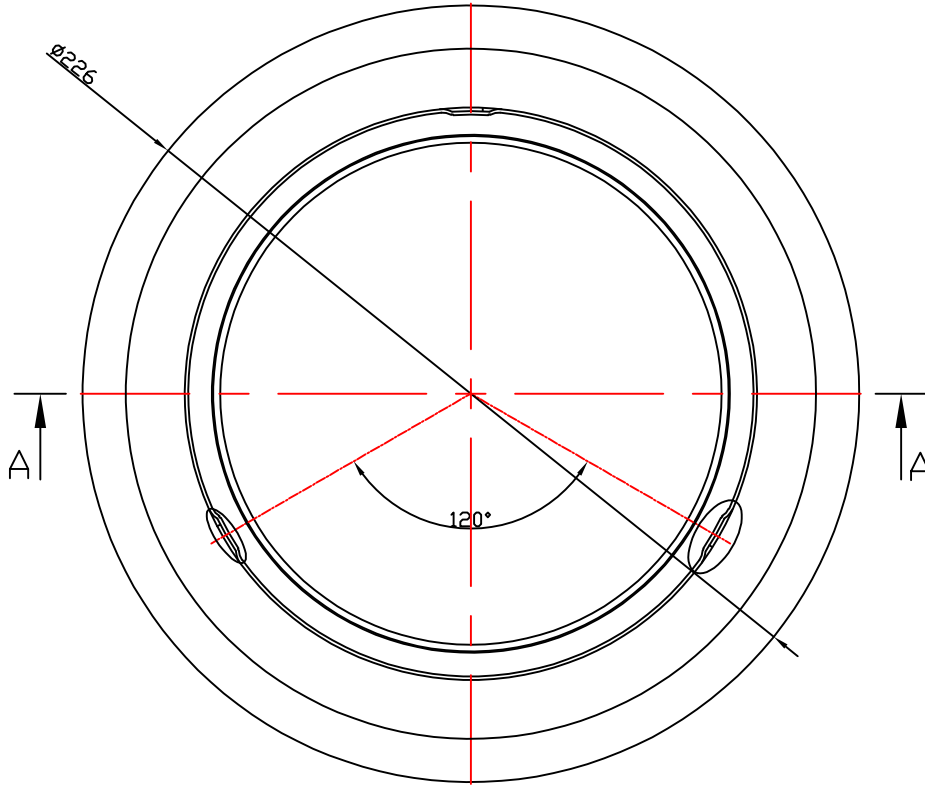
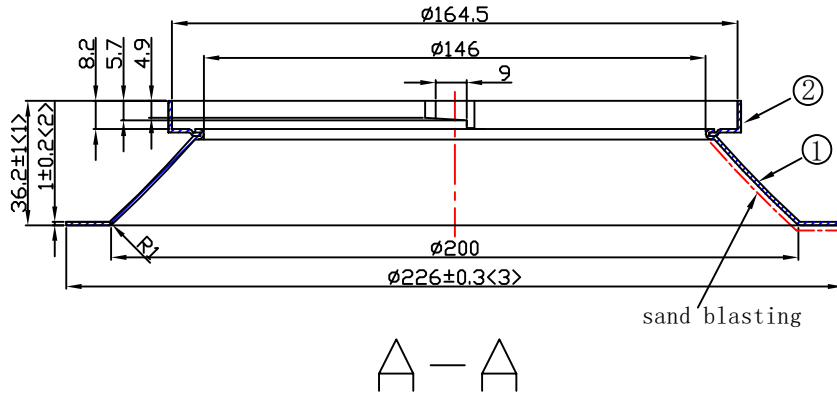

Light Source	PHILIPS DLM FS 20001i
PlasticHolder	
Metal Adaptor	
Design Angle	90° ±5°
Measured Angle	
Efficiency	

				Nata® NATA Lighting Co.,Ltd			
Mark	Amended Times	Amended Content		Signature	Amended Date	Customer Item	
Controll Version	A0	Design Version	K0	Client Version		Customer Code	NT
Designer		Drawing by		Proportion	1:1	Product Number	
Technology		Auditor		View		Product Name	8-0352-M
Approval		Date	2018 10 20	Page	Total Page		