

DIMENSION TOLERANCE TABLE (UNLESS OTHERWISE STATED) (MM)				PUNCH TOLERANCE TABLE (UNLESS OTHERWISE STATED) (ANGLE)		
> 0-5	> 5-30	> 30-90	> 90-150	0-10	10-50	50-120
±0.15	±0.2	±0.4	±0.5	±1°	±0.5°	±0.3°
> 150-250	> 250-400	> 400-700		120-250	250-360	
±0.8	±1.5	±2		±0.2°	±0.166°	

“*” KEY CONTROL DIMENSION

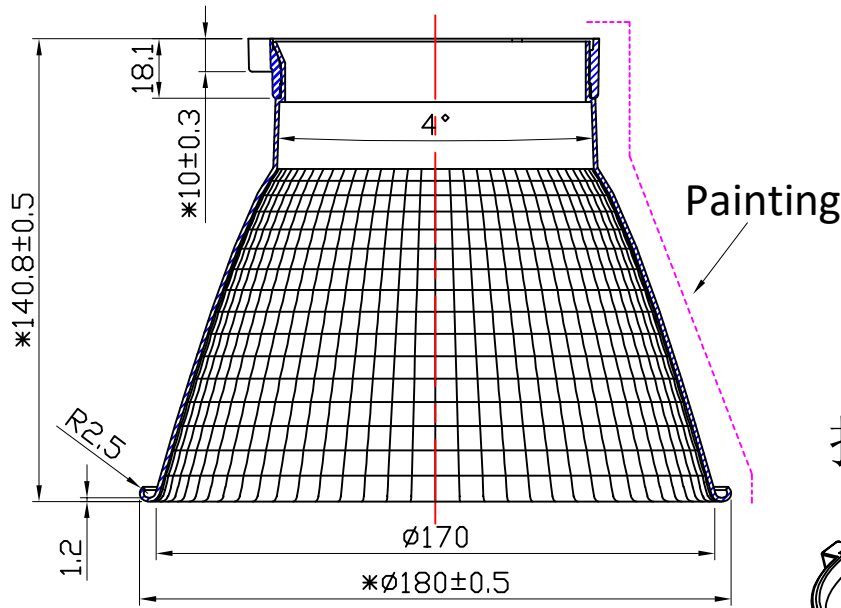

A-A

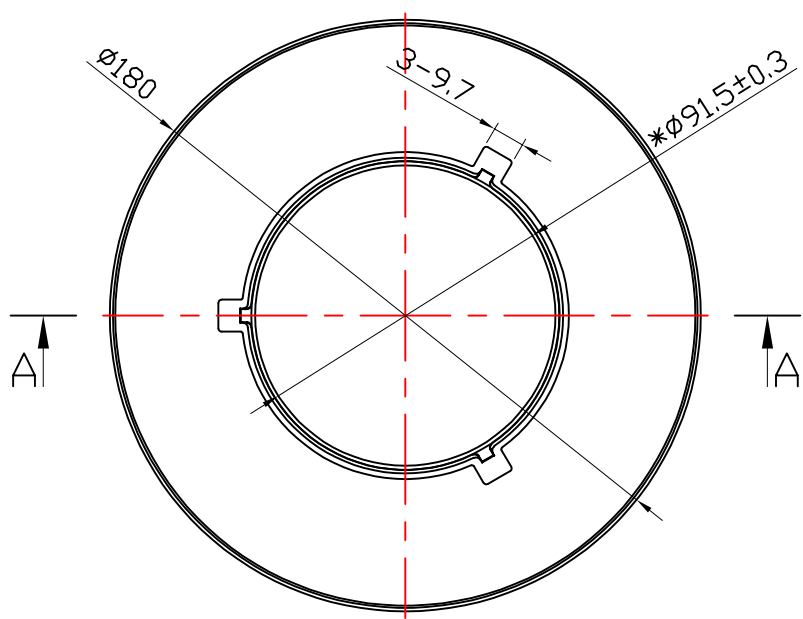

LIGHT SOURCE	COB 200W LES 33mm (2700K-6000K)
PLASTIC HOLDER	
METAL ADAPTAR	
DESIGNED B.A.	35°±3°
MEASURED B.A.	33.8°
EFFICIENCY	

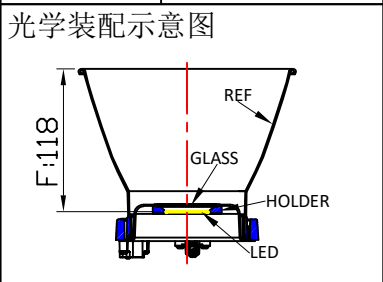

标记	1	更改内容	签名	更改日期
MARK	NO.OF MODIF.	MODIFICATIONS	SIGNED BY	MODIF. DATE
设计		制图	比例	1:1
DESIGNER		DRAWN BY	SCALE	
工艺		审核	视角	1st ANGLE PROJECTION
TECHNICIAN		CHECKED BY	页数	SHEET 1 OF 3
批准		日期		
APPROVED BY		DATE (DD-MM-YYYY)		

MATERIAL: T=1.2MM 1070AL FINISH: ANDOIZING+Painting		P/N: 91.07.0813.000	版本/REV KO
		产品名称 PRODUCT NAME	7-0813-M
		客户代号 CUSTOMER ID	NT
		客户编号 CUSTOMER CODE	
ENGINEERING DRAWING			Nata