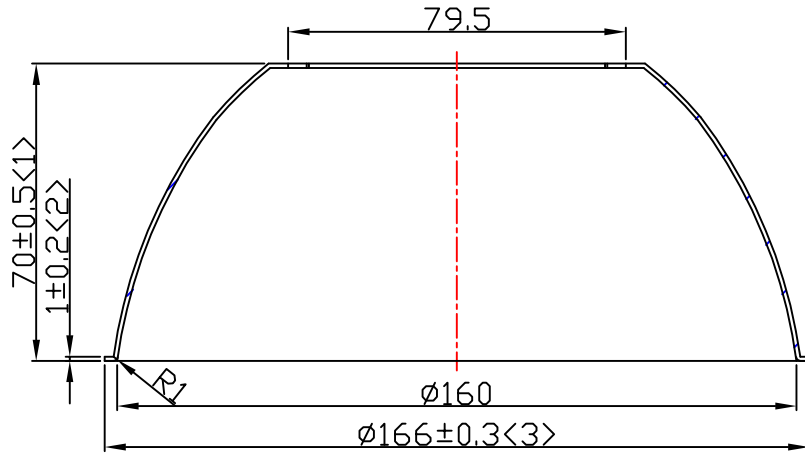
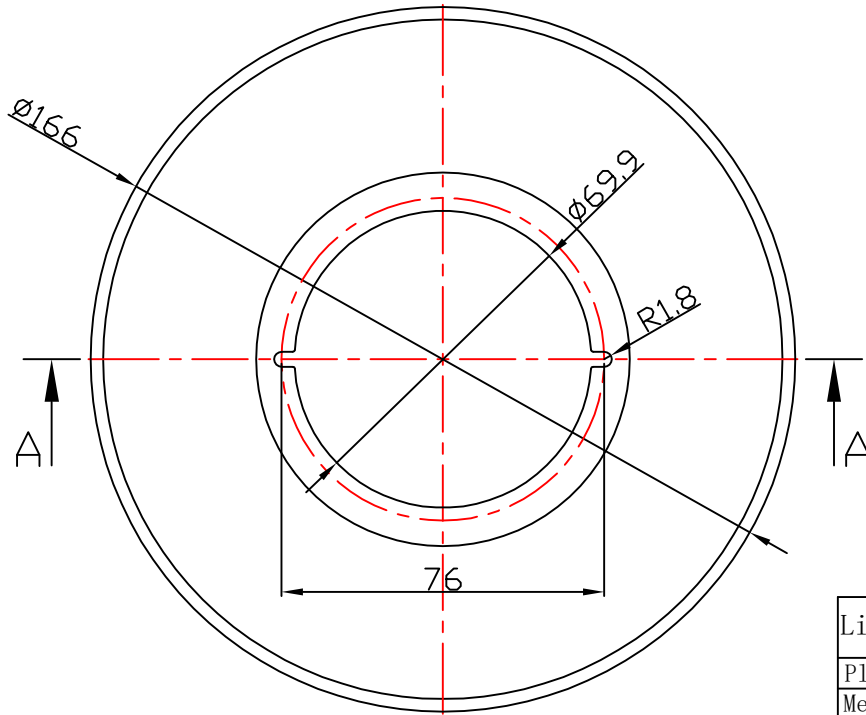

table for unmentioned tolerance in the drawing (unit: mm)			punch angle tolerance in the drawing (unit:degree)		
0-5	5-30	30-120	0-10	10-50	50-120
±0.15	±0.2	±0.5	±1°	±0.5°	±0.3°
120-250	250-400	400-700	120-250	250-360	360 above
±0.8	±1.5	±2	±0.2°	±0.166°	±0.083°



A-A



Light Source	PHILIPS DLM 20001m LES64
PlasticHolder	
Metal Adaptar	
Design Angle	60° ±5°
Measured Angle	58.8
Efficiency	

Product Name	Describe
6740-A	OD170, H70, 半哑光
6740-A2	OD170, H70, 亮光

Mark	Amended Times	Amended Content	Signature	Amended Date
Controll Version	AO	Design Version KO	Client Version	
Designer		Drawing by	Proportion	1:1
Technology		Auditor	View	
Approval		Date	Page	Total_Page_

Material:T=1.0  
1090AL

**Nata**<sup>®</sup>  
**NATA Lighting Co.,Ltd**

Customer Item	
Customer Code	NT
Product Number	
Product Name	6740-A2