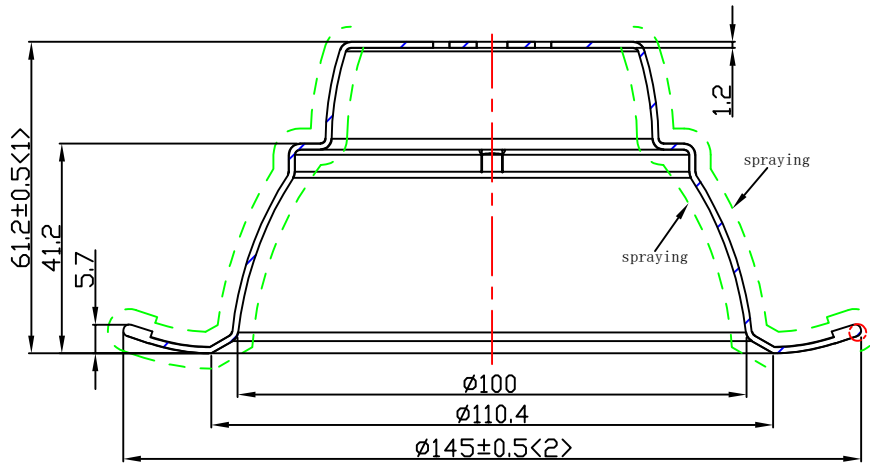
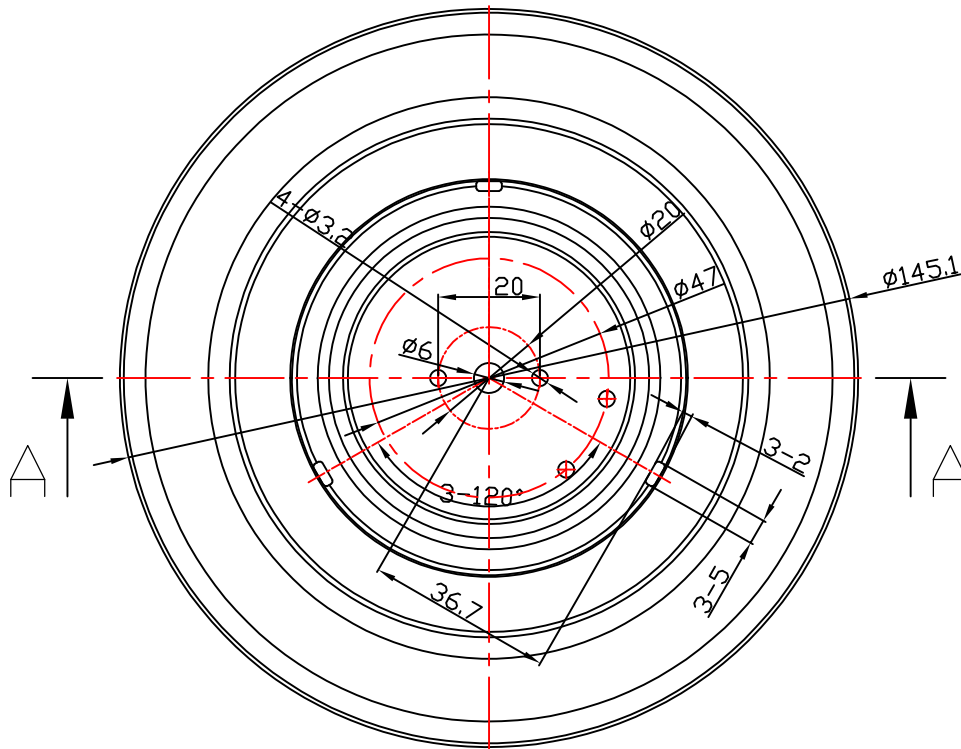

table for unmentioned tolerance in the drawing (unit: mm)			punch angle tolerance in the drawing (unit:degree)		
0-5	5-30	30-120	0-10	10-50	50-120
±0.15	±0.2	±0.5	±1°	±0.5°	±0.3°
120-250	250-400	400-700	120-250	250-360	360 above
±0.8	±1.5	±2	±0.2°	±0.166°	±0.083°



A-A



					Material: T=1.2 1070AL					Nata[®] NATA Lighting Co.,Ltd		
												Customer Item
Mark	Amended Times	Amended Content			Signature	Amended Date					Customer Code	NT
Control Version	A0	Design Version	K0		Client Version						Product Number	
Designer		Drawing by			Proportion	1:1					Product Name	5937-P
Technology		Auditor			View							
Approval		Date	2019.06.18		Page	Total Page						