

Product bill of material				
Serial number	Material Name	Masterial Number	NO.	Describe
①	5-1086-S	91.05.1086.000	1	Material:PC
②	五合一PC防尘片	97.70.169.00	1	Material:PC
③	5-1070-S	94.05.1070.000	1	Material:PC

table for unmentioned tolerance in the drawing (unit: mm)					
0-5	5-30	30-120	120-250	250-400	400-700
±0.15	±0.2	±0.5	±0.8	±1.5	±2

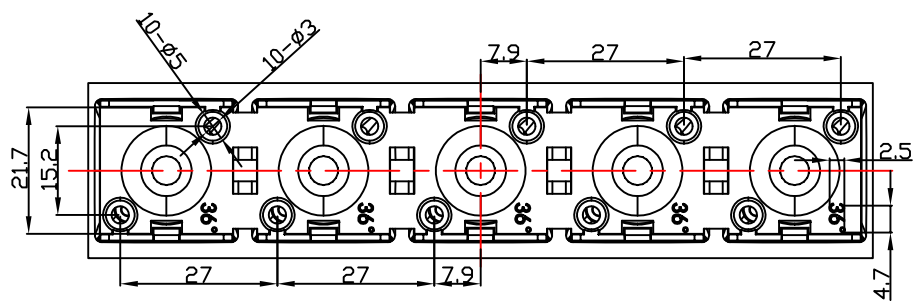

字码标识:
 字体: 黑体
 字长: 4.7mm
 字宽: 2.5mm
 字深: 0.15mm

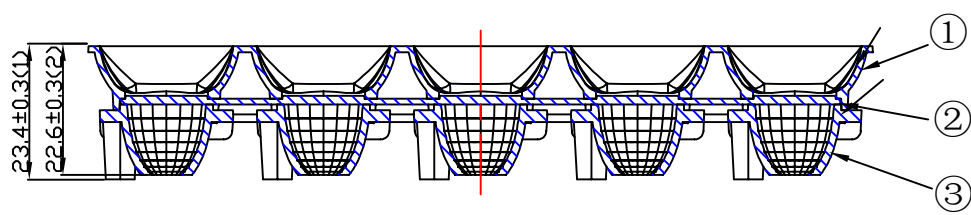

A-A

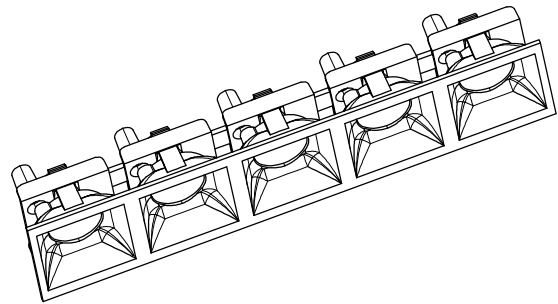
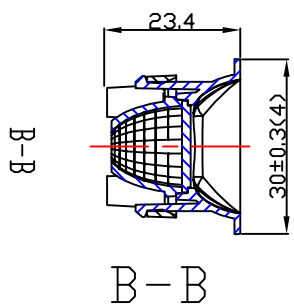
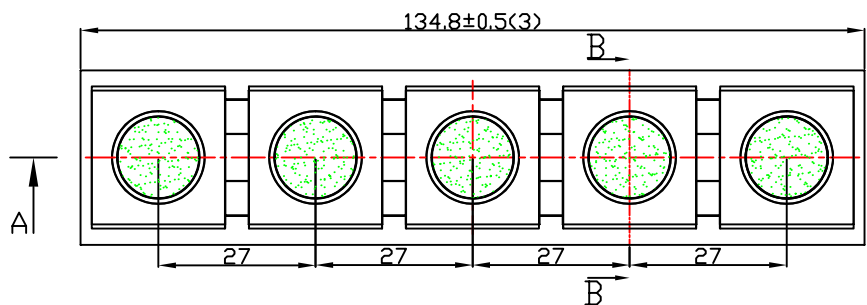

Light Source	CREE XP-E2
PlasticHolder	
Adaptar	
Design Angle	36° ±3°
Measured Angle	36.4°
Efficiency	

光学装配示意图

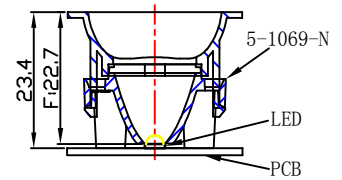

Approval						Customer Item	
Mark	Amended Times	Amended Content		Signature	Amended Date	Customer Item	
Control Version	A0	Design Version	K2	Client Version		Customer Code	NT
Designer		Drawing by		Proportion	1:1	Product Number	
Technology		Auditor		View		Product Name	5-1069-N
Approval		Date	2018.08.25	Page	Total_Page_		

组装图

Nata[®]
NATA Lighting Co.,Ltd