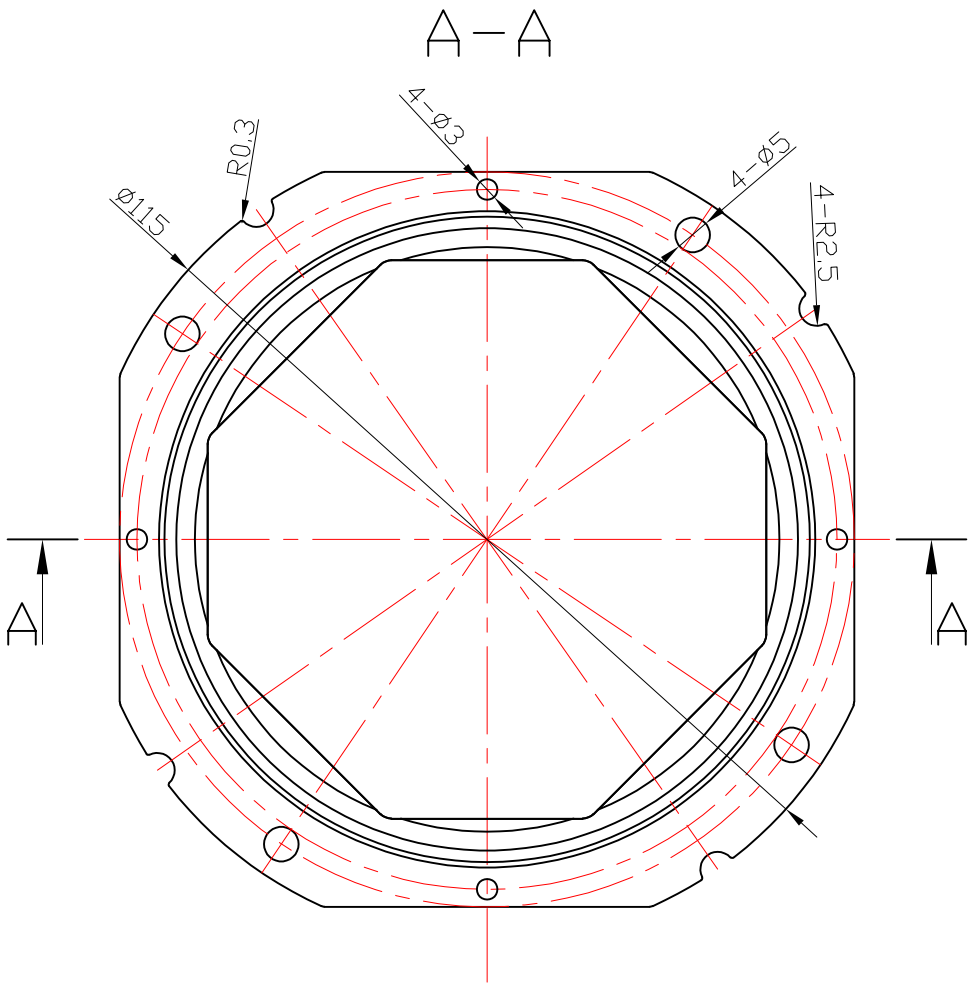
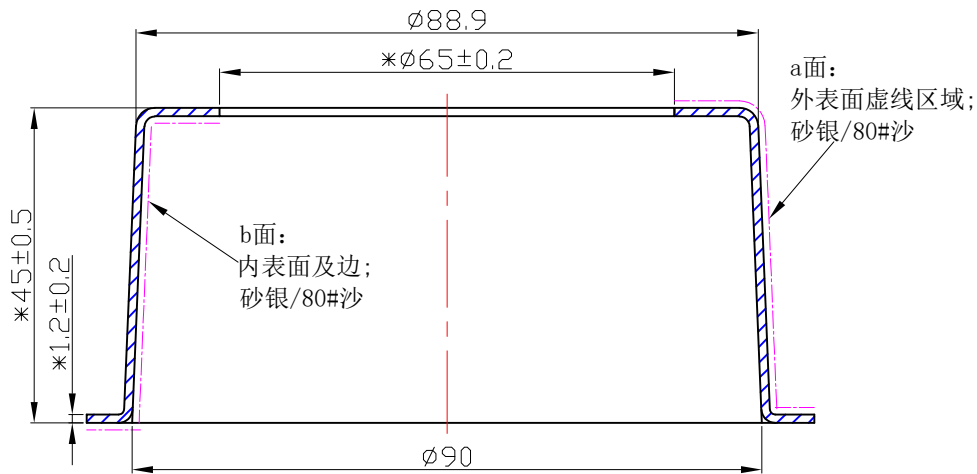

table for unmentioned tolerance in the drawing (unit: mm)				punch angle tolerance in the drawing (unit:degree)		
>0-5	>5-30	>30-90	>90-150	0-10	10-50	50-120
±0.15	±0.2	±0.4	±0.5	±1°	±0.5°	±0.3°
>150-250	>250-400	>400-700		120-250	250-360	360 above
±0.8	±1.5	±2		±0.2°	±0.166°	±0.085°

“\*” Marked for key control dimensions



MATERIAL: T=1.2MM 1090AL  
FINISH: Sandblasting+ANDOIZING

P/N: 91.04.2631.001  
版本/REV: KO

产品名称: 4-2631-F2

客户代号: NT

客户编号: 115光源固定罩-异形孔

标记	1	更改内容	签名	更改日期
MARK	NO. OF MODIF.	MODIFICATIONS	SIGNED BY	MODIF. DATE
设计		制图	比例	1:1
DESIGNER		DRAWN BY	SCALE	
工艺		审核	视角	
TECHNICAN		CHECKED BY	1st ANGLE PROJECTION	
批准		日期	页数	1
APPROVED BY		DATE(DD-MM-YYYY)	PAGE	SHEET 1 OF 1
		07-10-2022		

ENGINEERING DRAWING

