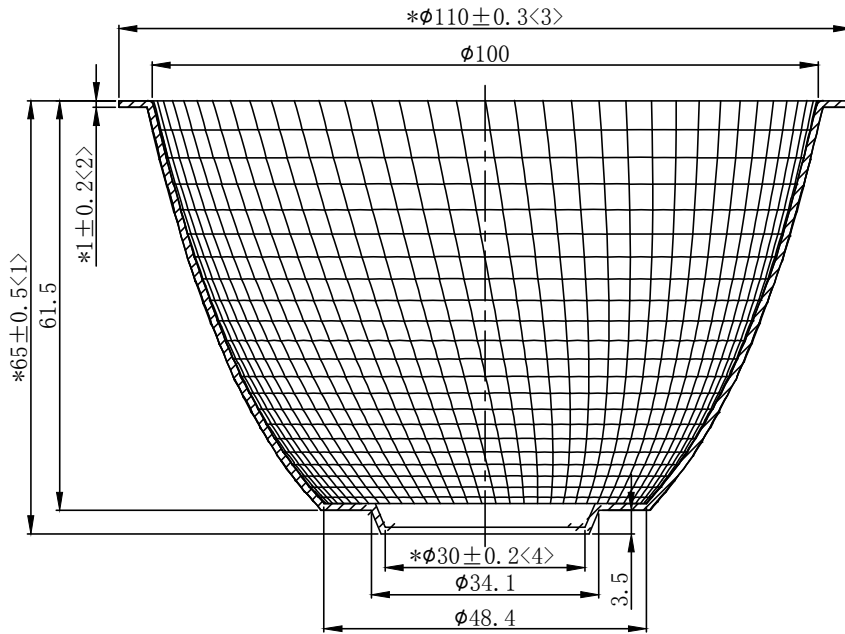
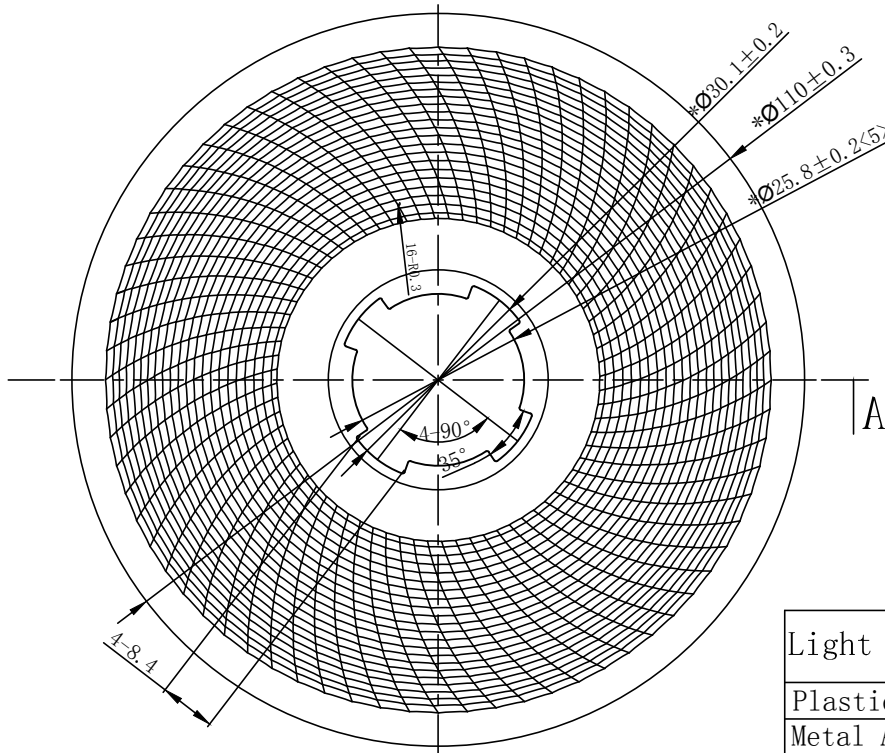

table for unmentioned tolerance in the drawing (unit: mm)			punch angle tolerance in the drawing (unit:degree)		
0-5	5-30	30-120	0-10	10-50	50-120
±0.15	±0.2	±0.5	±1°	±0.5°	±0.3°
120-250	250-400	400-700	120-250	250-360	360 above
±0.8	±1.5	±2	±0.2°	±0.166°	±0.083°

" ( ) " Important size



A-A



Light Source	LUMENS
PlasticHolder	
Metal Adaptar	92.76.319.00
Design Angle	19° ±3°
Measured Angle	18.8°

Material:T=1.0 1090AL

**Nata**® Lighting Co., Ltd

Mark	Amended Times	Amended Content	Signature	Amended Date	Customer Item
Controll Version	A0	Design Version	K0	Client Version	Customer Code
Designer	C	Drawing by		Proportion	1:1
Technology		Auditor		View	Product Number
Approval		Date	2018.11.05	Page	Total_Page_
					Product Name