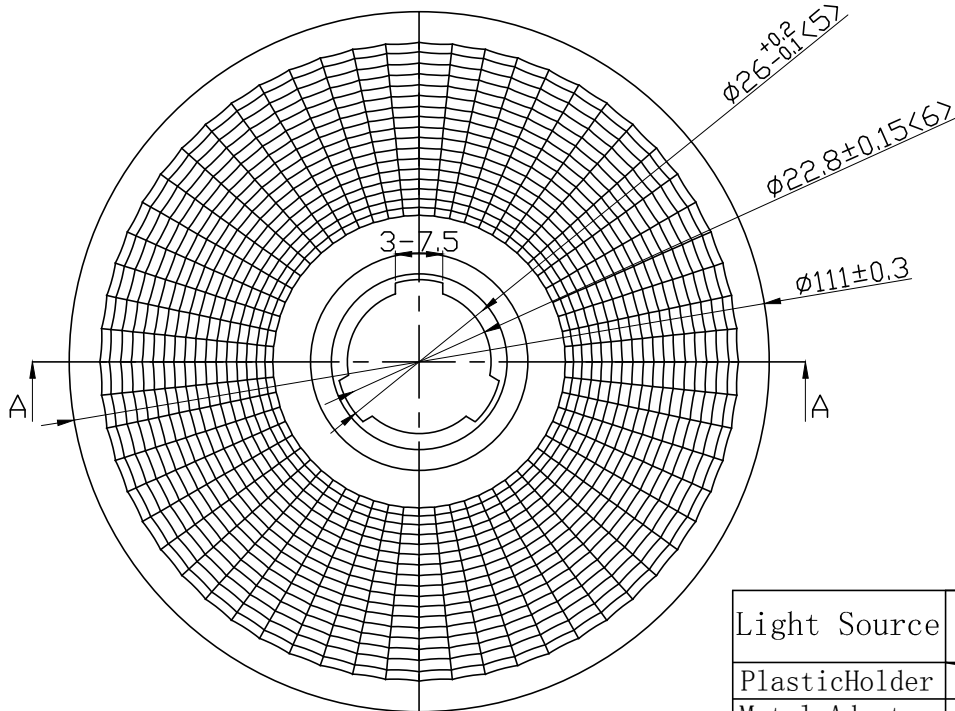
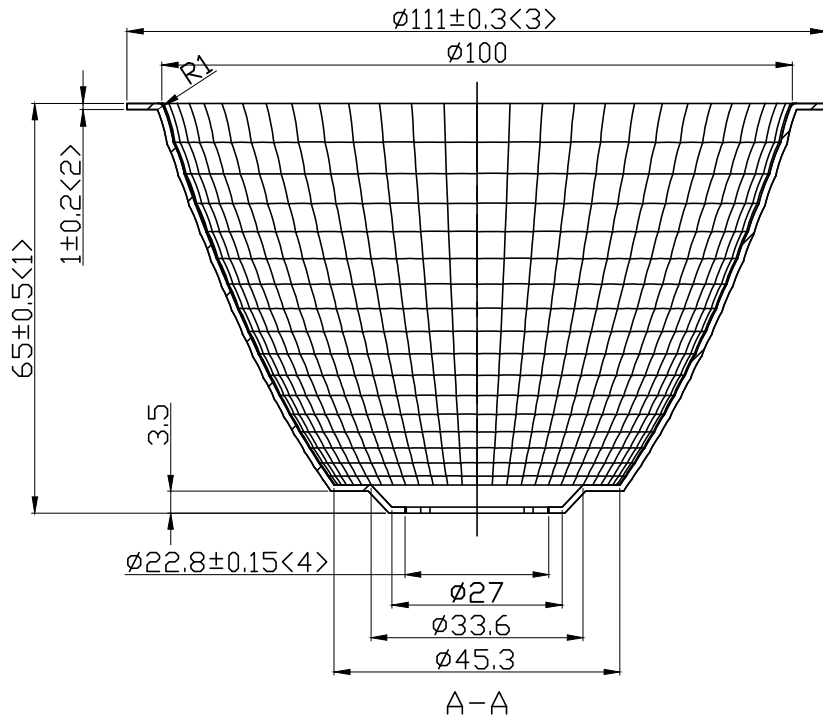

table for unmentioned tolerance in the drawing (unit: mm)			punch angle tolerance in the drawing (unit:degree)		
0-5	5-30	30-120	0-10	10-50	50-120
±0.15	±0.2	±0.5	±1°	±0.5°	±0.3°
120-250	250-400	400-700	120-250	250-360	360 above
±0.8	±1.5	±2	±0.2°	±0.166°	±0.083°

"<" Important size



Light Source	GE
PlasticHolder	
Metal Adaptar	92.76.233.00
Design Angle	24° ±3°
Measured Angle	21.2°

					Material:T=1.0 1090AL					<b>Nata</b> ® Lighting Co., Ltd					
Mark	Amended Times	Amended Content			Signature			Amended Date			Customer Item				
Controll Version	A0	Design Version	K0	Client Version				1:1			Customer Code		NT		
Designer	C	Drawing by			Proportion						Product Number		91.04.1890.000		
Technology		Auditor			View						Product Name		4-1890-A		
Approval		Date	2018.11.05	Page	Total_ Page_										