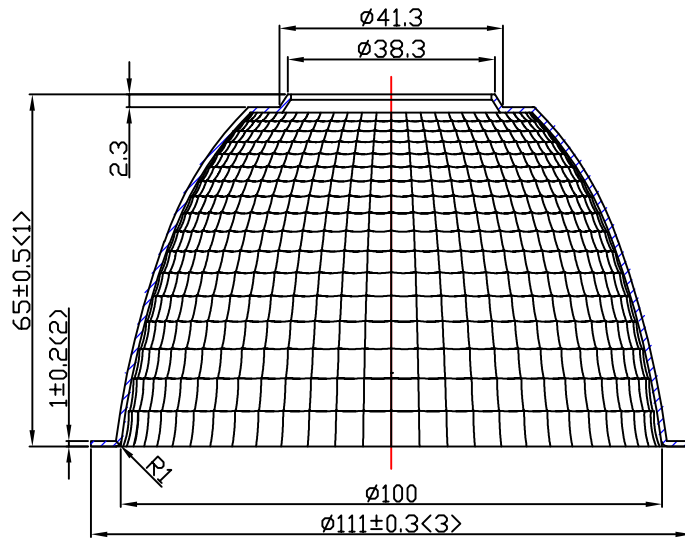
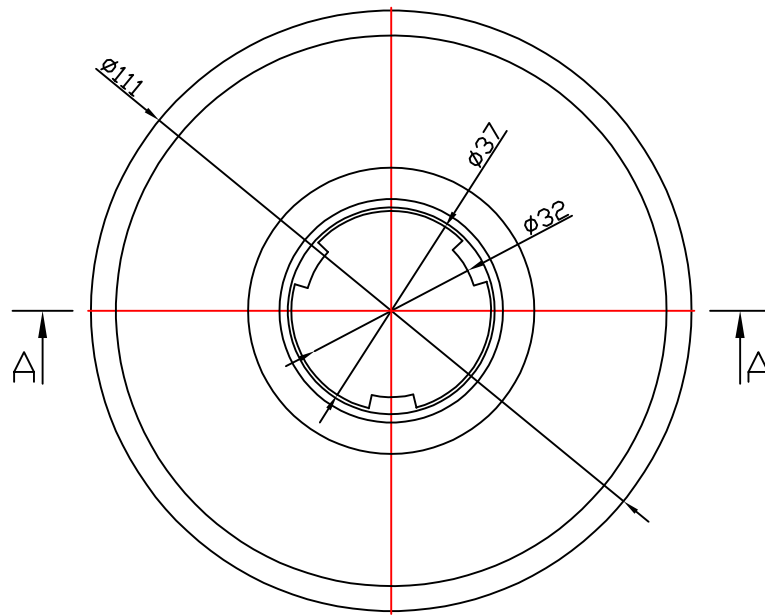

table for unmentioned tolerance in the drawing (unit: mm)			punch angle tolerance in the drawing (unit:degree)		
0-5	5-30	30-120	0-10	10-50	50-120
±0.15	±0.2	±0.5	±1°	±0.5°	±0.3°
120-250	250-400	400-700	120-250	250-360	360 above
±0.8	±1.5	±2	±0.2°	±0.166°	±0.083°



A-A



Light Source	BRIDGELUX Vero 29
PlasticHolder	
Metal Adaptar	92.76.227.00
Design Angle	55° ±5°
Measured Angle	56.2°
Efficiency	

				Material:T=1.0 1090AL				 NATA Lighting Co.,Ltd	
Mark	Amended Times	Amended Content		Signature	Amended Date		Customer Code		NT
Controll Version	AO	Design Version	KO	Client Version			Product Number		
Designer		Drawing by		Proportion	1:1		Product Name		4-1820-E
Technology		Auditor		View					
Approval		Date	2018.02.27	Page	Total_Page_				