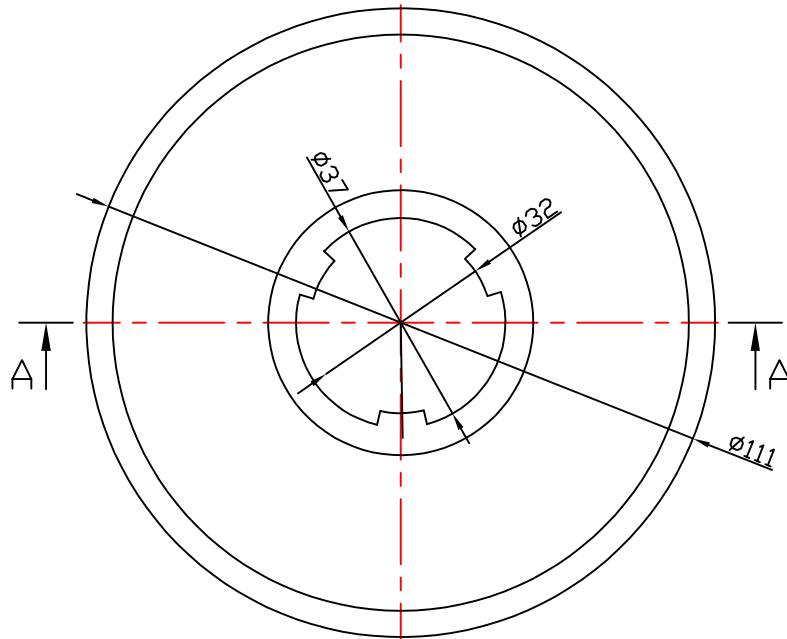
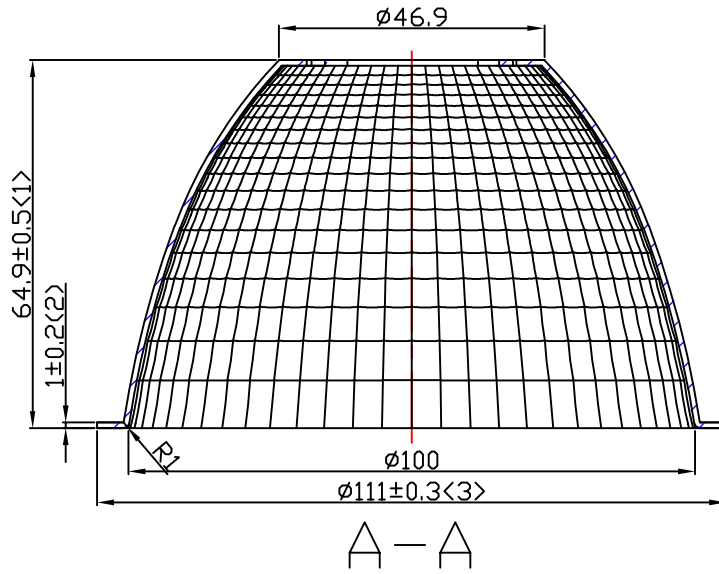

table for unmentioned tolerance in the drawing (unit: mm)			punch angle tolerance in the drawing (unit:degree)		
0-5	5-30	30-120	0-10	10-50	50-120
±0.15	±0.2	±0.5	±1°	±0.5°	±0.3°
120-250	250-400	400-700	120-250	250-360	360 above
±0.8	±1.5	±2	±0.2°	±0.166°	±0.083°



Light Source	Bridgelux Vero 29
PlasticHolder	
Metal Adaptor	92.76.227.00
Design Angle	40° ±5°
Measured Angle	39.4°
Efficiency	

					Material:T=1.0 1090AL		Nata [®] NATA Lighting Co.,Ltd	
Mark	Amended Times	Amended Content		Signature	Amended Date	Customer Item		
Controll Version	AO	Design Version	K0	Client Version		Customer Code		NT
Designer		Drawing by		Proportion	1:1	Product Number		
Technology		Auditor		View		Product Name		4-1666-E
Approval		Date	2014. 11. 12	Page	Total_ Page_			