

Product bill of material				
Serial number	material name	Material number	NO.	Describe
①	3-1970-S	94.03.1970.000	1	Material:PC
②	D85镜面防尘片	97.70.146.00	1	Material:PC

table for unmentioned tolerance in the drawing (unit: mm)					
0-5	5-30	30-120	120-250	250-400	400-700
±0.15	±0.2	±0.5	±0.8	±1.5	±2

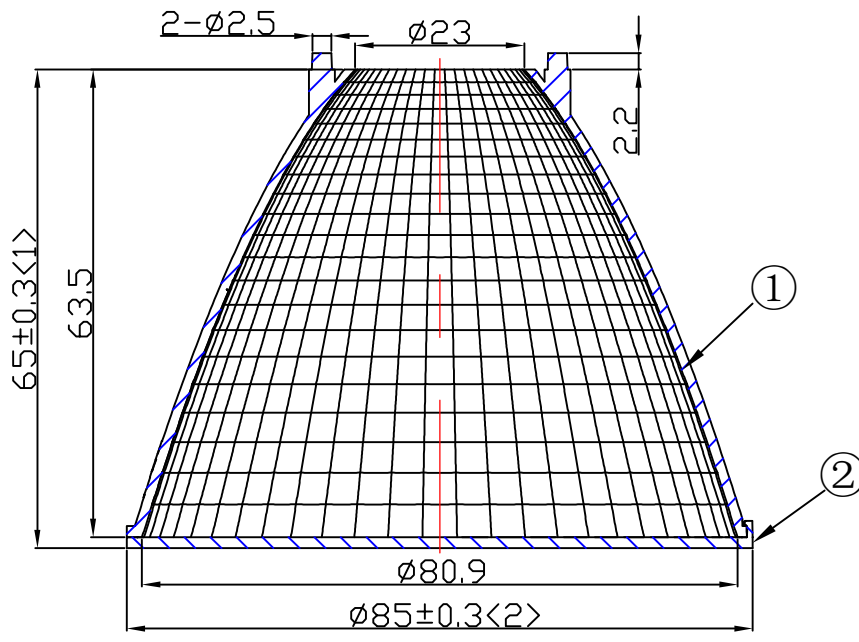

A-A

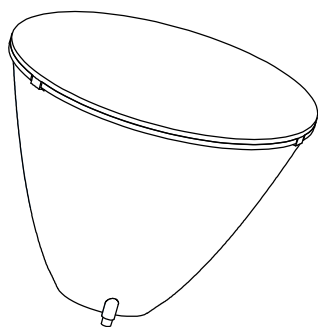
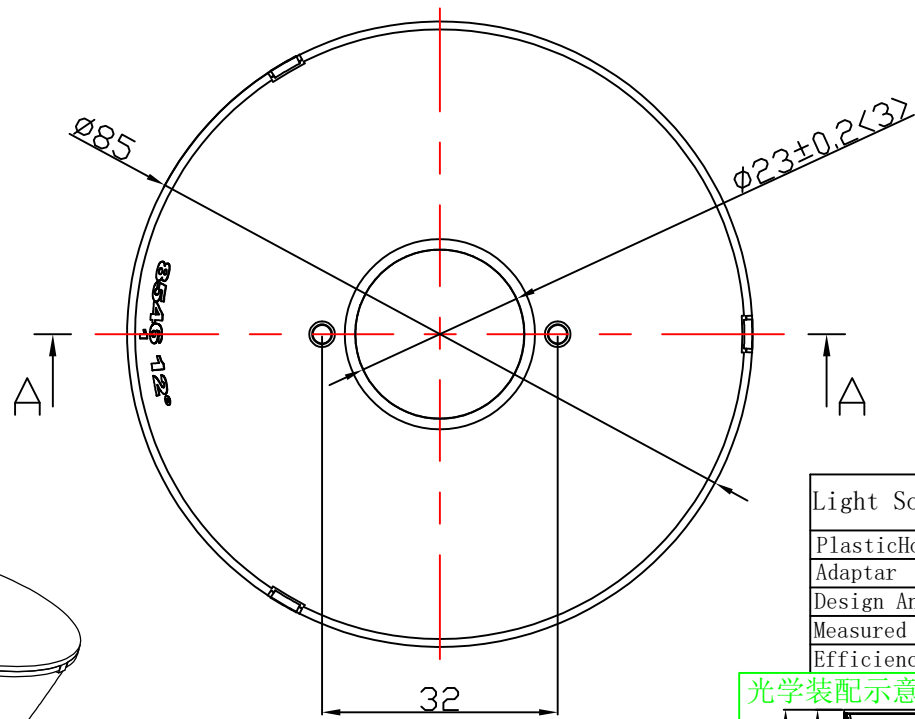

Light Source	LUMILEDS LUXEON CoB 120
PlasticHolder	92.70.135.00
Adaptar	
Design Angle	15° ±3°
Measured Angle	15.2°
Efficiency	

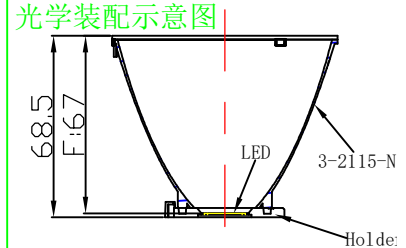

					Material:PC		Nata® NATA Lighting Co.,Ltd	
Mark	Amended Times	Amended Content		Signature	Amended Date	Customer Item		
Control Version	AO	Design Version	K1	Client Version		Customer Code	NT	
Designer		Drawing by		Proportion	1:1	Product Number		
Technology		Auditor		View		Product Name	3-2115-N	
Approval		Date	2018.09.29	Page	Total Page_			