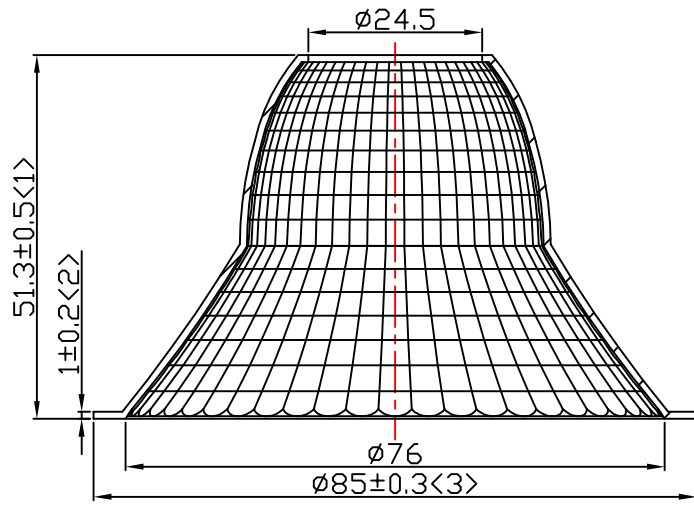
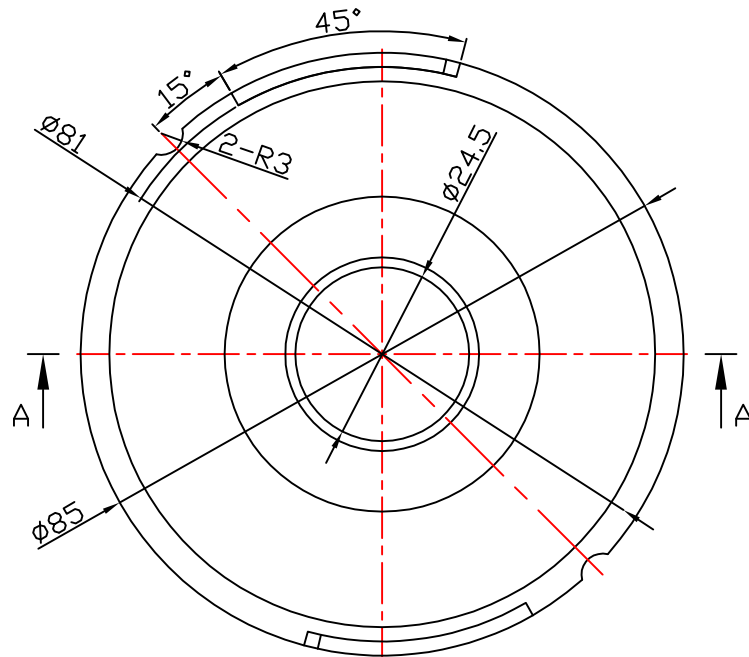

table for unmentioned tolerance in the drawing (unit: mm)			punch angle tolerance in the drawing (unit:degree)		
0-5	5-30	30-120	0-10	10-50	50-120
±0.15	±0.2	±0.5	±1°	±0.5°	±0.3°
120-250	250-400	400-700	120-250	250-360	360 above
±0.8	±1.5	±2	±0.2°	±0.166°	±0.083°



A - A



Light Source	PHILIPS SLM 1211 G6
PlasticHolder	
Metal Adaptor	
Design Angle	$60^\circ \pm 5^\circ$
Measured Angle	62.6°
Efficiency	

Material:T=1.0
1090AL

Nata[®]
NATA Lighting Co.,Ltd

Mark	Amended Times	Amended Content		Signature	Amended Date	Customer Item	
Version	A0	Design Version	K0	Client Version		Customer Code	NT
Designer		Drawing by		Proportion	1:1	Product Number	
Technology		Auditor		View		Product Name	3-2071-A
Approval		Date	2017.06.24	Page	Total Page		