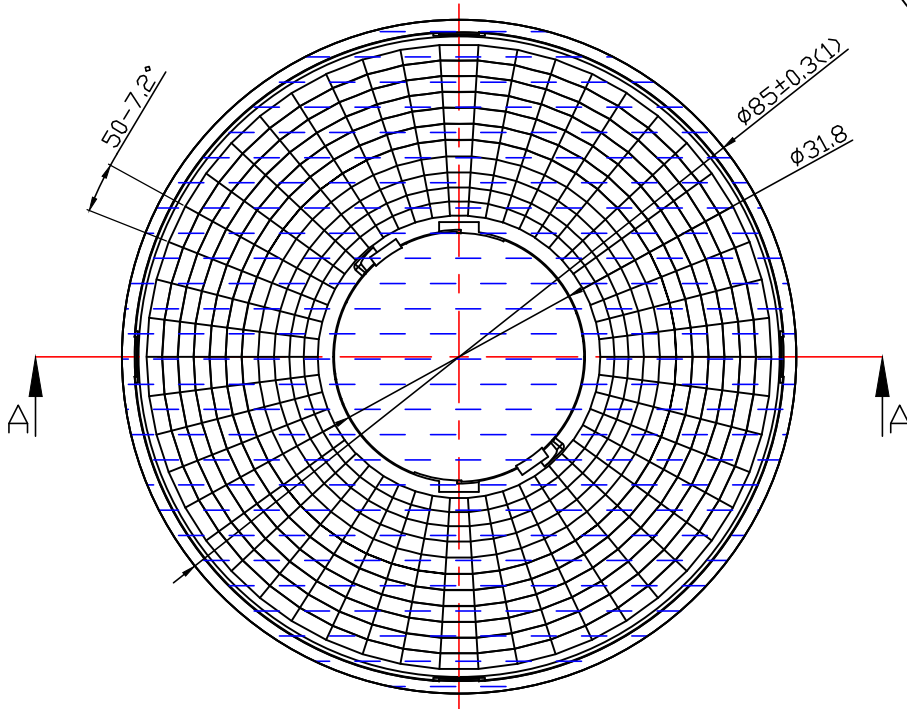
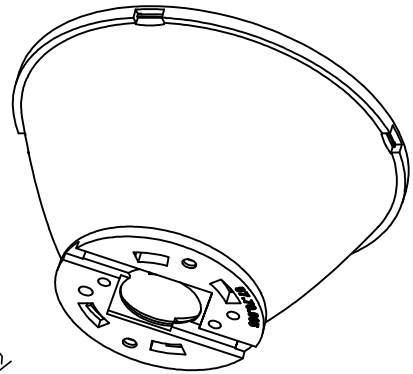
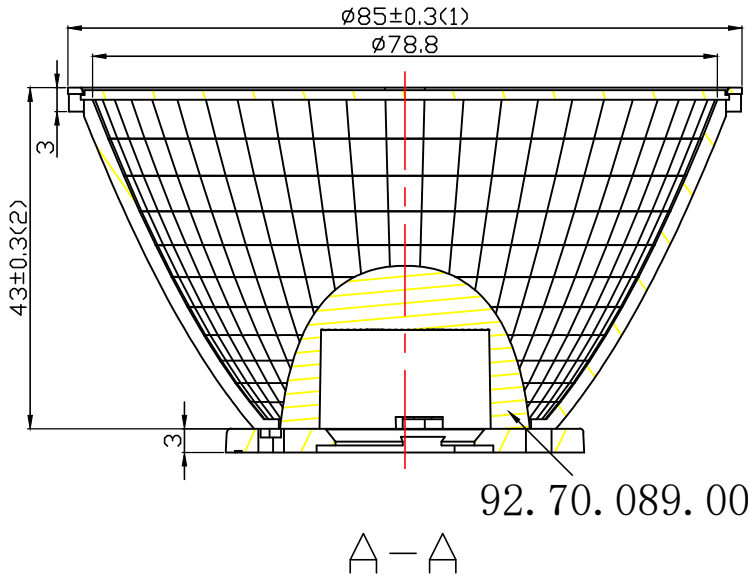

table for unmentioned tolerance in the drawing (unit: mm)			punch angle tolerance in the drawing (unit: degree)		
0-5	5-30	30-120	0-10	10-50	50-120
±0.15	±0.2	±0.5	±1°	±0.5°	±0.3°
120-250	250-400	400-700	120-250	250-360	360 above
±0.8	±1.5	±2	±0.2°	±0.166°	±0.083°

"<" Important size



Light Source	CREE CXA2520
PlasticHolder	92.70.045.00
lens	92.70.089.00
Design Angle	$21^\circ \pm 3^\circ$
Measured Angle	$21.8^\circ$

Bill of material				
Number	Item	Code	Quantity	Material
①	reflector	94.03.2064.000	1	PC
②	dust cover	92.70.062.00	1	PC

Approval						Material:PC		Nata <sup>®</sup> Lighting Co., Ltd	
Mark	Amended Times	Amended Content		Signature	Amended Date	Customer Item	OD85mm PC Reflector		
Controll Version	A0	Design Version	K0	Client Version		Customer Code	NT		
Designer	JL	Drawing by		Proportion	1:1	Product Number	91.03.1698.000		
Technology		Auditor		View		Product Name	3-1698-N		
Approval		Date	2018.10.26	Page	Total_Page_				