

参考用图

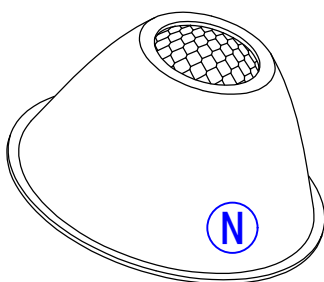

A-A

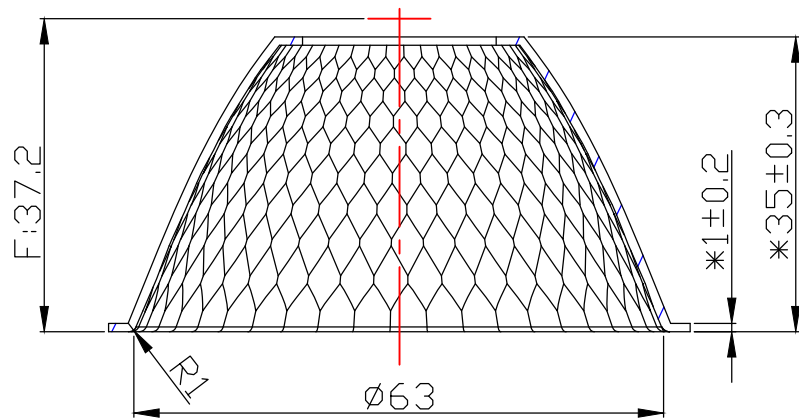
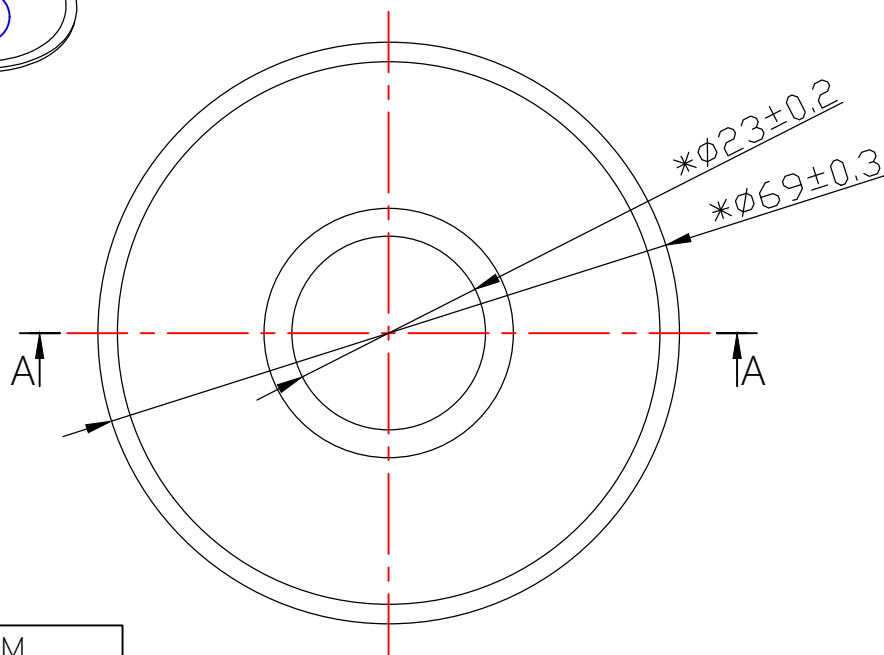

Light Source	CITIZEN CLU038
PlasticHolder	92.70.121.00
Metal Adapter	
Design Angle	18°±2°
Measured Angle	
Efficiency	

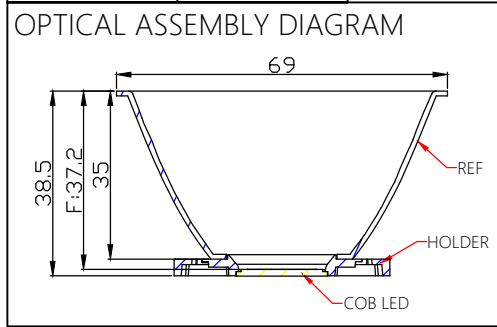

技术要求:

- 1.材质: T=1.0mm 1090AL。
- 2.表面处理: 亮光。
- 3."*"标记为重点控制尺寸。
- 4.未注公差按公差表。
- 5.产品未注圆角与拔模斜度按3D。
- 6.产品外观按《N-SIP-QA-04 铝反光杯检验标准》。

MARK	NO.OF MODIF.	更改内容 MODIFICATIONS	签名 SIGNED BY	更改日期 MODIF. DATE
DESIGNER		制图 DRAWN BY	比例 SCALE	1:1
TECHNICAN		审核 CHECKED BY	视角 1st ANGLE PROJECTION	
APPROVED BY		日期 DATE(DD-MM-YYYY)	页数 PAGE	SHEET 1 OF 1

DIMENSION TOLERANCE TABLE(UNLESS OTHERWISE STATED) 未注尺寸公差表						
> 0-5	> 5-30	> 30-90	> 90-150	> 150-250	> 250-400	> 400-700
±0.15	±0.2	±0.4	±0.5	±0.8	±1.5	±2
PUNCH TOLERANCE TABLE (UNLESS OTHERWISE STATED) (ANGLE) 角度公差表 (单位: 度)						
> 0-10	> 10-50	> 50-120	> 120-250	> 250-360		
±1°	±0.5°	±0.3°	±0.2°	±0.166°		
产品图 PRODUCT DRAWING					单位 UNIT	mm

Nata [®]		版本 VERSIONS	V1.0
产品编码 PRODUCT CODE	91.02.3210.000		
产品名称 PRODUCT NAME	2-3210-A		
客户 CUSTOMER	NT		
客户产品编号 CUSTOMER PRODUCT CODE	BT69-N-23H35 铝杯		