

Item NO.	Product Name	Product NO.	QTY	Page	Description
①	EW76.750.10 固定卡环	97.76.750.10	1	4	t=1.0mm 1060AL, Andoizing.
②	2-2433-H		1	2	t=1.2mm 1090AL, Andoizing.
③	EW-75透明片	97.70.365.00	1	3	PC

table for unmentioned tolerance in the drawing (unit: mm)				punch angle tolerance in the drawing (unit: degree)		
> 0-5	> 5-30	> 30-90	> 90-150	0-10	10-50	50-120
±0.15	±0.2	±0.4	±0.5	±1°	±0.5°	±0.3°
> 150-250	> 250-400	> 400-700		120-250	250-360	360 above
±0.8	±1.5	±2		±0.2°	±0.166°	±0.085°

“*” Marked for key control dimensions

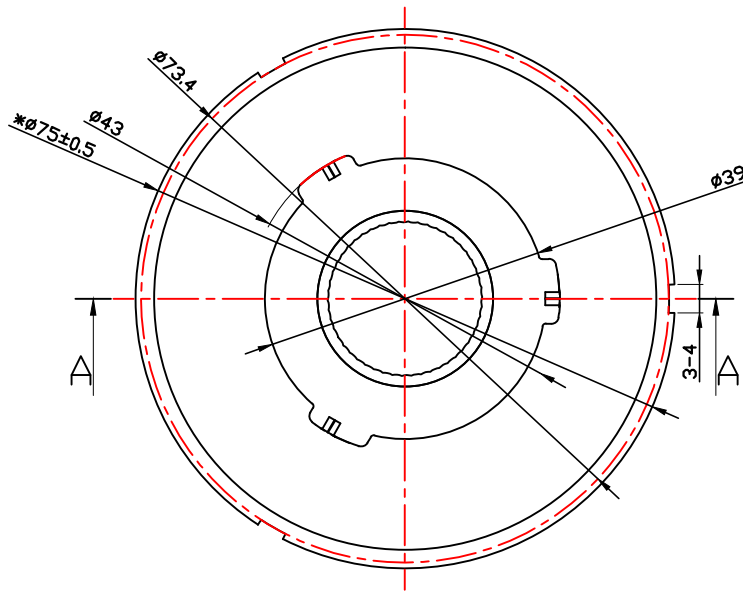
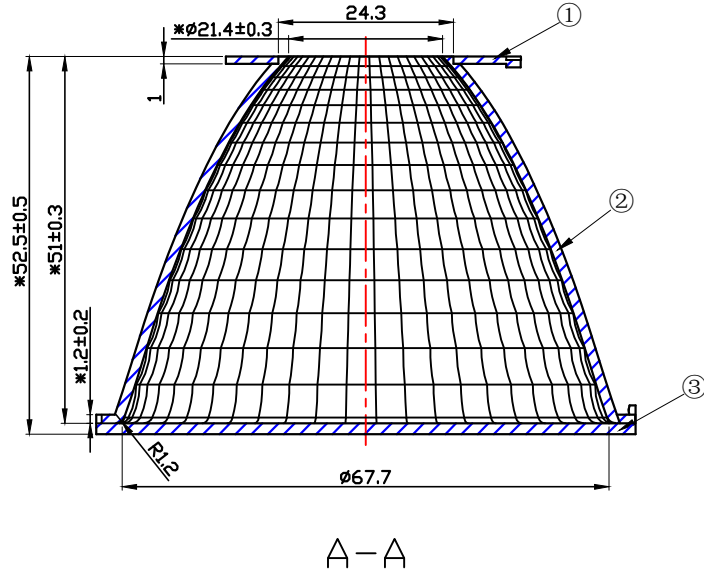

Light Source	CITIZEN CLU038
Plastic Holder	92.70.131.00
Metal Adaptor	
Design Angle	36° ±3°
Measured Angle	
Efficiency	

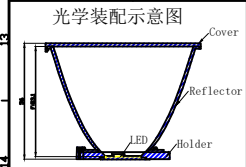

Technical requirements:
 1. Material: AL.
 2. Surface treatment: Andoizing..
 3. Product untolerance reference untolerance table.

				P/N: 91.02.2432.000		版本/REV K2
				产品名称 Product Name		2-2432-M
				客户代号 Customer Code		NT
				客户编号 Customer Item		EW-36°
标记 Mark	处数 Issued Times	更改内容 Amended Content	签名 Signature	更改日期 Amended Date	工程图 Engineering drawings	
设计 Designer	区工	制图 Drawing by	比例 Proportion	1:1		
工艺 Technology		审核 Auditor	视角 View			
批准 Approval		日期 Date	页 数 Page	共1页 第1页		
				图档路径 The path of file	Nata®	