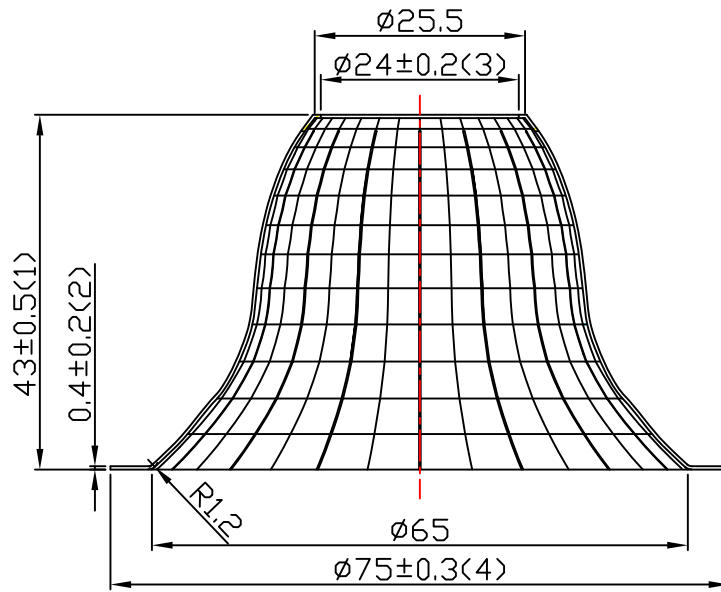
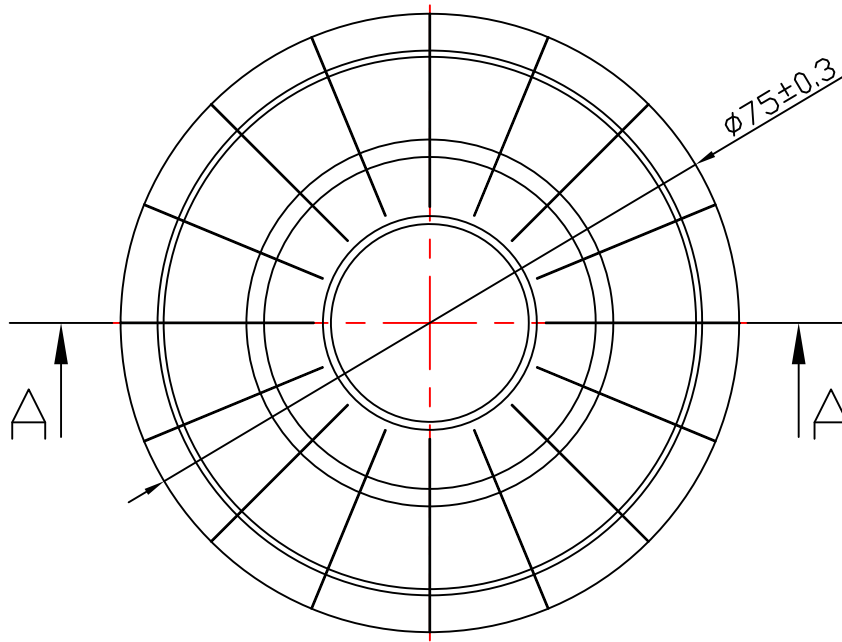

table for unmentioned tolerance in the drawing (unit: mm)			punch angle tolerance in the drawing (unit:degree)		
0-5	5-30	30-120	0-10	10-50	50-120
±0.15	±0.2	±0.5	±1°	±0.5°	±0.3°
120-250	250-400	400-700	120-250	250-360	360 above
±0.8	±1.5	±2	±0.2°	±0.166°	±0.083°



A-A



Light Source	CREE CXA1820
Plastic Holder	92.70.129.00
Metal Adapter	
Design requirement	60° ± 3°
Measured result	57.6°

光学示意图

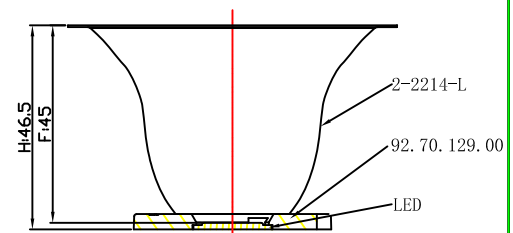

Material: Miro 98AX4

Nata[®]

Mark	Amended Times	Amended Content		Signature	Amended Date
Control Version	A0	Design Version	K1	Client Version	
Designer		Drawing by		Proportion	1:1
Technology		Auditor		View	
Approval		Date	2020.03.12	Page	Total Page_

Customer Item	OD75mm安铝反光杯60°
Customer Code	NT
Product Number	91.02.2214.000
Product Name	2-2214-L