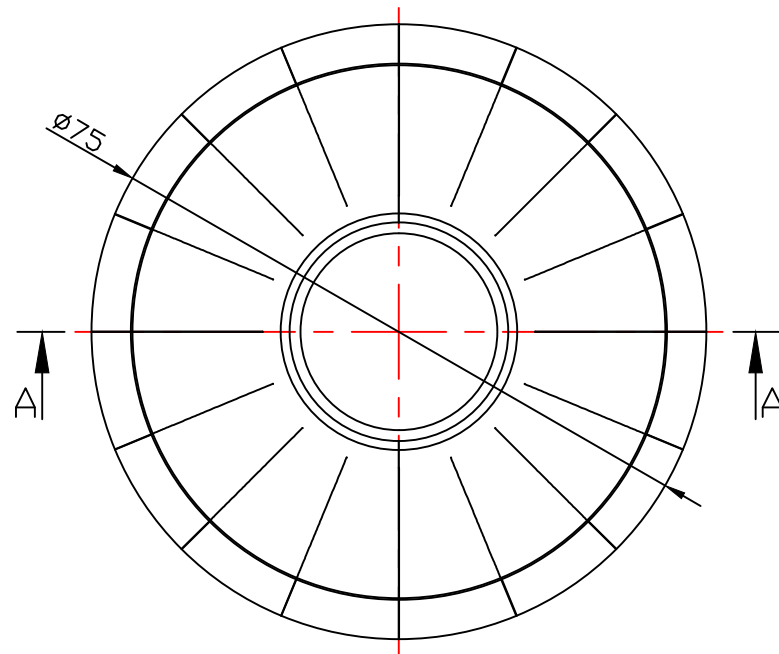
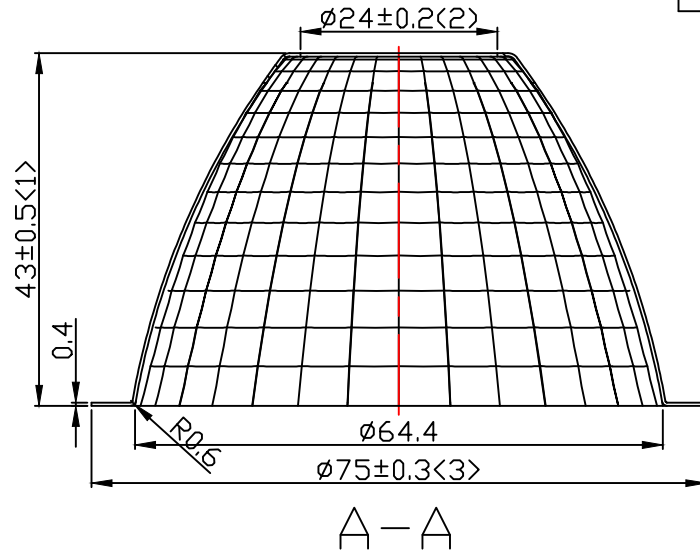
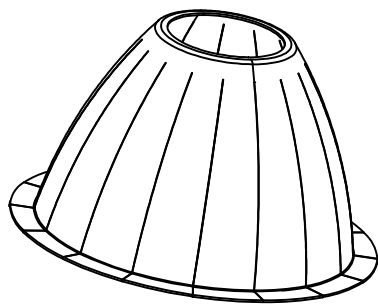

table for unmentioned tolerance in the drawing (unit: mm)			punch angle tolerance in the drawing (unit:degree)		
0-5	5-30	30-120	0-10	10-50	50-120
±0.15	±0.2	±0.5	±1°	±0.5°	±0.3°
120-250	250-400	400-700	120-250	250-360	360 above
±0.8	±1.5	±2	±0.2°	±0.166°	±0.083°



Light Source	CREE CXA1820
PlasticHolder	92. 70. 129. 00
Metal Adaptor	
Design Angle	26° ±3°
Measured Angle	26.3°
Efficiency	



光学装配示意图

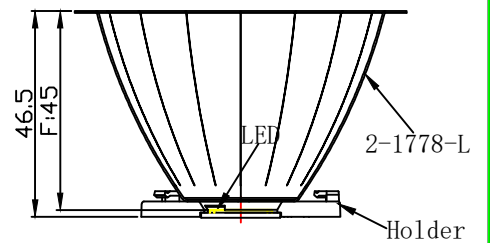

Material:T=0.4  
MIRO 98AX4

**Nata**<sup>®</sup>  
**NATA Lighting Co.,Ltd**

Mark	Amended Times	Amended Content		Signature	Amended Date
Control Version	A0	Design Version	K0	Client Version	
Designer		Drawing by		Proportion	1:1
Technology		Auditor		View	
Approval		Date	2018.03.16	Page	Total_Page_

Customer Item	
Customer Code	NT
Product Number	
Product Name	2-1778-L