

| table for unmentioned tolerance in the drawing (unit: mm) |         |         | punch angle tolerance in the drawing (unit:degree) |         |           |
|-----------------------------------------------------------|---------|---------|----------------------------------------------------|---------|-----------|
| 0-5                                                       | 5-30    | 30-120  | 0-10                                               | 10-50   | 50-120    |
| ±0.15                                                     | ±0.2    | ±0.5    | ±1°                                                | ±0.5°   | ±0.3°     |
| 120-250                                                   | 250-400 | 400-700 | 120-250                                            | 250-360 | 360 above |
| ±0.8                                                      | ±1.5    | ±2      | ±0.2°                                              | ±0.166° | ±0.083°   |

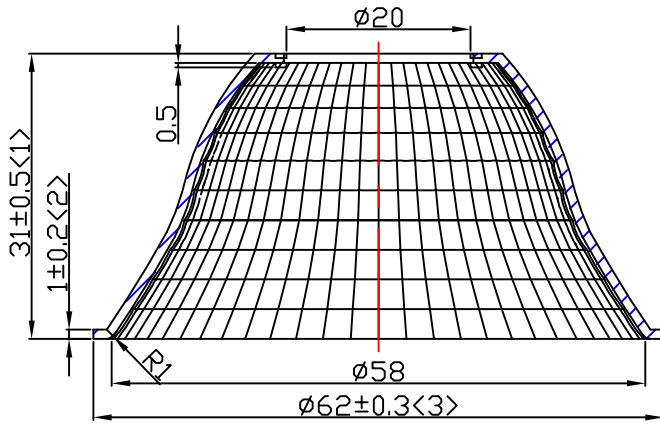

A - A

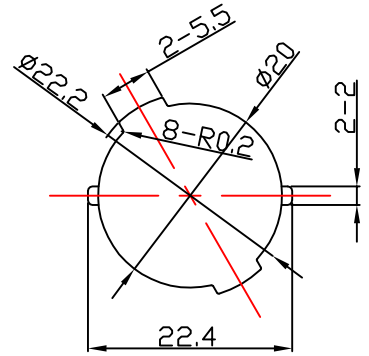
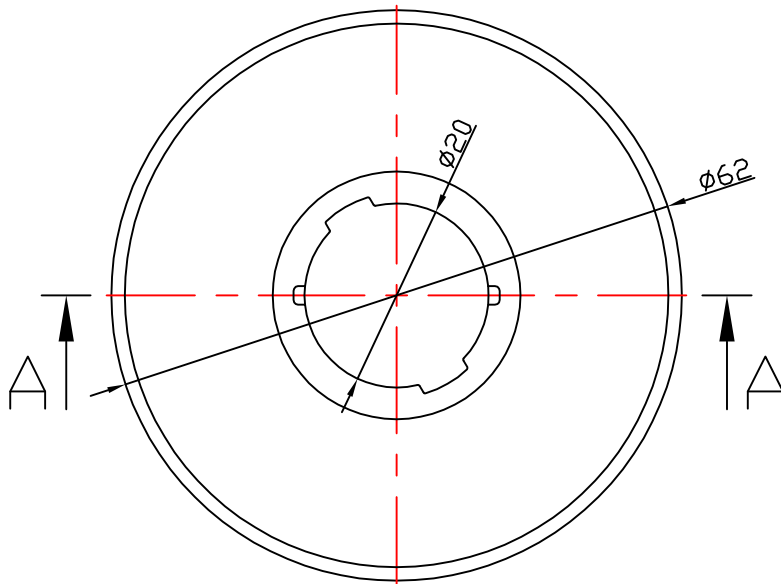

底孔视图 1:1

|                |                        |
|----------------|------------------------|
| Light Source   | CREE CXA1507<br>LES8.9 |
| PlasticHolder  | 92.70.046.00           |
| Metal Adapter  |                        |
| ADAPTER        | 92.70.147.00           |
| Design Angle   | 38° ±3°                |
| Measured Angle | 38.9°                  |
| Efficiency     |                        |

光学装配示意图

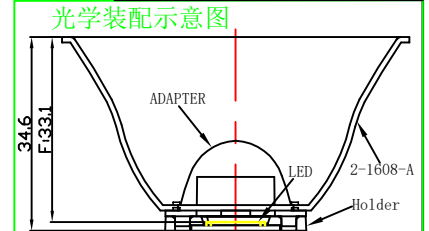

Material:T=1.0  
1090AL

**Nata**<sup>®</sup>  
**NATA Lighting Co.,Ltd**

|                  |               |                 |            |                |              |                |          |
|------------------|---------------|-----------------|------------|----------------|--------------|----------------|----------|
| Mark             | Amended Times | Amended Content |            | Signature      | Amended Date | Customer Item  |          |
| Controll Version | AO            | Design Version  | KO         | Client Version |              | Customer Code  | NT       |
| Designer         |               | Drawing by      |            | Proportion     | 1:1          | Product Number |          |
| Technology       |               | Auditor         |            | View           |              | Product Name   | 2-1608-A |
| Approval         |               | Date            | 2018.02.07 | Page           | Total Page   |                |          |