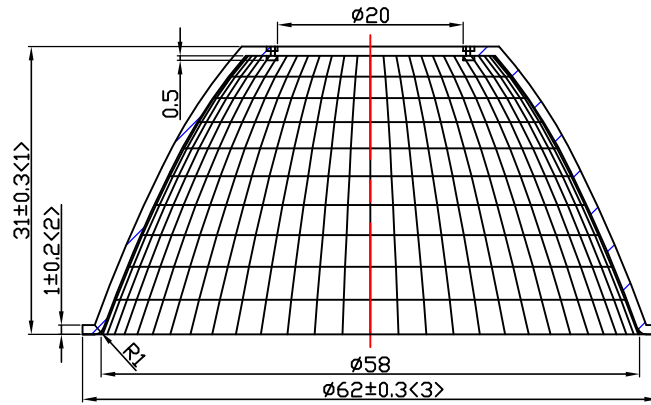
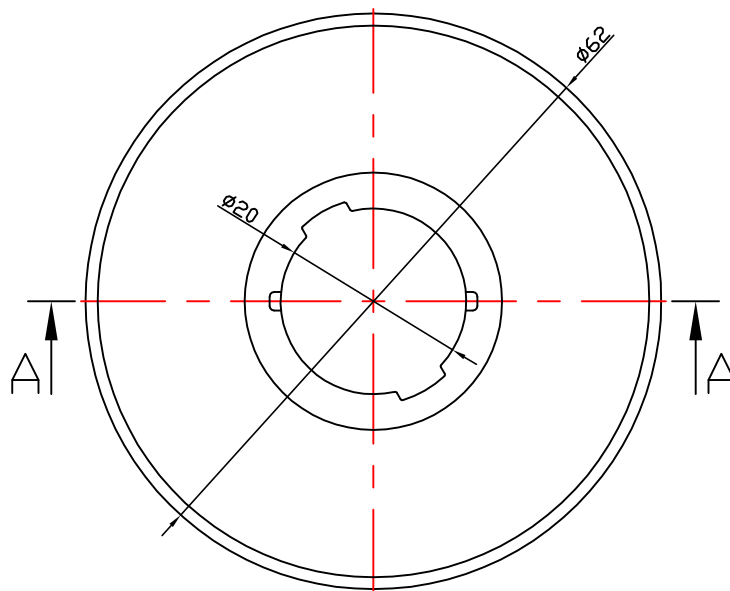

table for unmentioned tolerance in the drawing (unit: mm)			punch angle tolerance in the drawing (unit:degree)		
0-5	5-30	30-120	0-10	10-50	50-120
±0.15	±0.2	±0.5	±1°	±0.5°	±0.3°
120-250	250-400	400-700	120-250	250-360	360 above
±0.8	±1.5	±2	±0.2°	±0.166°	±0.083°



A - A



Light Source	CREE CXA1507 LESS. 9
PlasticHolder	92.70.046.00
Metal Adapter	
ADAPTER	92.70.147.00
Design Angle	$15^\circ \pm 3^\circ$
Measured Angle	12.2°
Efficiency	

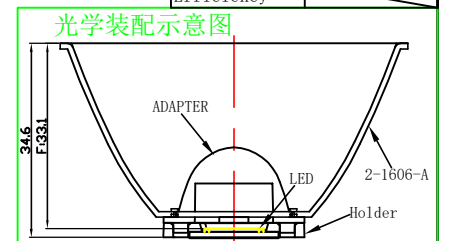

Material:T=1.0
1090AL

Nata[®]
NATA Lighting Co.,Ltd

Mark	Amended Times	Amended Content	Signature	Amended Date	Customer Item	
Controll Version	AO	Design Version KO	Client Version		Customer Code	NT
Designer		Drawing by	Proportion	1:1	Product Number	
Technology		Auditor	View		Product Name	2-1606-A
Approval		Date	Page	Total Page		
		2019.04.30				