

Product bill of material				
Serial number	material name	Masterial number	NO.	Describe
①	2-1577-A	94.02.1577.000	1	Material:T=1.0mm 1090AL
②	020360	97.76.360.00	1	Material:T=0.6mm SUS304

table for unmentioned tolerance in the drawing (unit: mm)			punch angle tolerance in the drawing (unit:degree)		
0-5	5-30	30-120	0-10	10-50	50-120
±0.15	±0.2	±0.5	±1°	±0.5°	±0.3°
120-250	250-400	400-700	120-250	250-360	360 above
±0.8	±1.5	±2	±0.2°	±0.166°	±0.083°

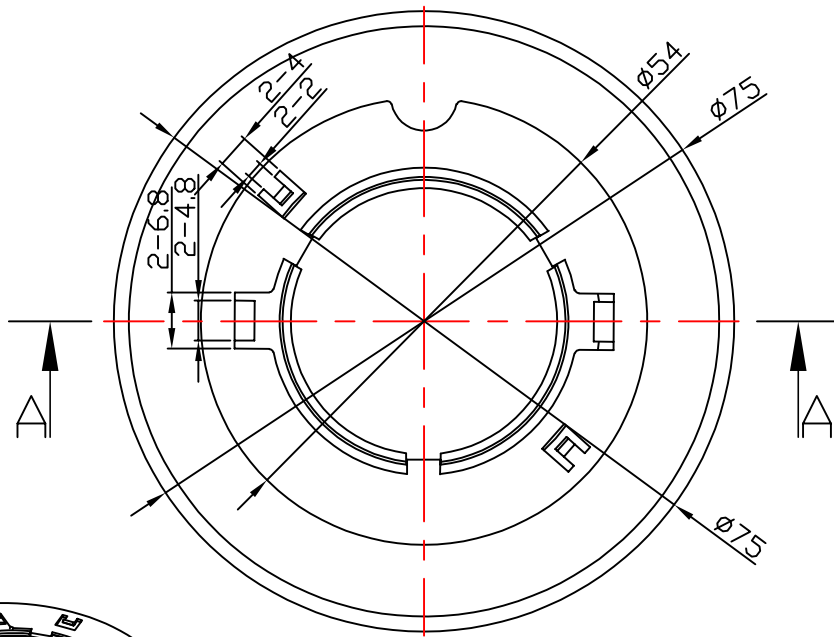

Light Source	LUMILEDS LUXEON CoB 1204 LES13
PlasticHolder	BJB 47.319.2011
Metal Adaptar	
Design Angle	15° ± 3°
Measured Angle	16.7°
Efficiency	

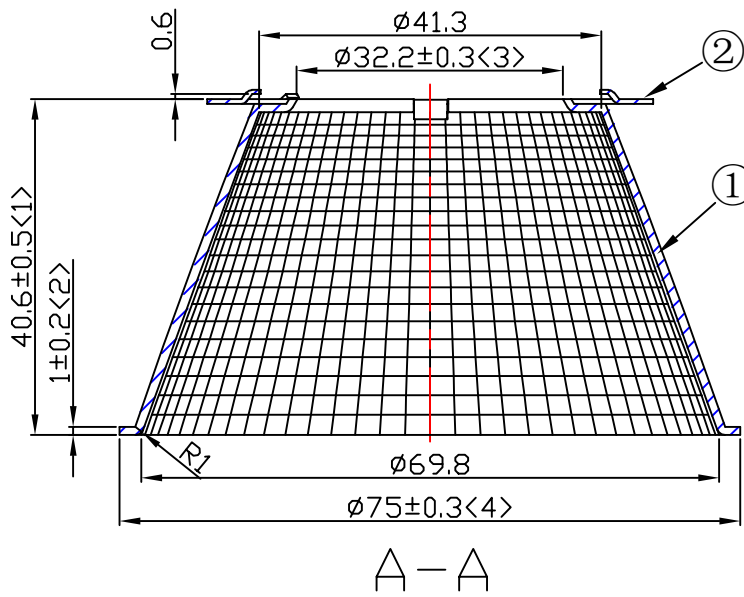
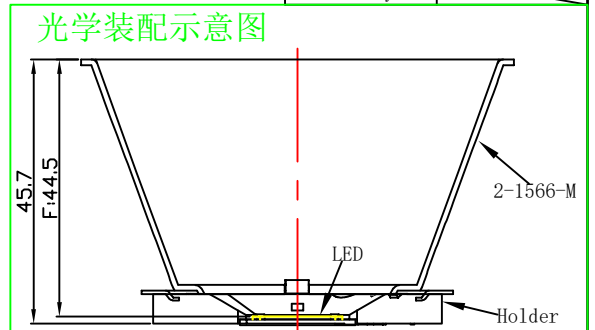
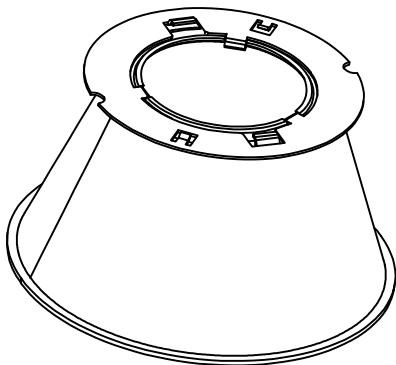

Mark	Amended Times	Amended Content		Signature	Amended Date
Controll Version	A0	Design Version	K0	Client Version	
Designer		Drawing by		Proportion	1:1
Technology		Auditor		View	
Approval		Date	2018.07.01	Page	Total_Page

Material:T=1.0
1090AL

Nata®
NATA Lighting Co.,Ltd

Customer Item	
Customer Code	NT
Product Number	
Product Name	2-1566-M