

Product bill of material				
Serial number	material name	Masterial number	NO.	Describe
①	2-1573-A	94.02.1573.000	1	Material:T=1.0mm 1090AL
②	020359	97.76.359.00	1	Material:T=0.6mm SUS304

table for unmentioned tolerance in the drawing (unit: mm)			punch angle tolerance in the drawing (unit:degree)		
0-5	5-30	30-120	0-10	10-50	50-120
±0.15	±0.2	±0.5	±1°	±0.5°	±0.3°
120-250	250-400	400-700	120-250	250-360	360 abov
±0.8	±1.5	±2	±0.2°	±0.166°	±0.083°

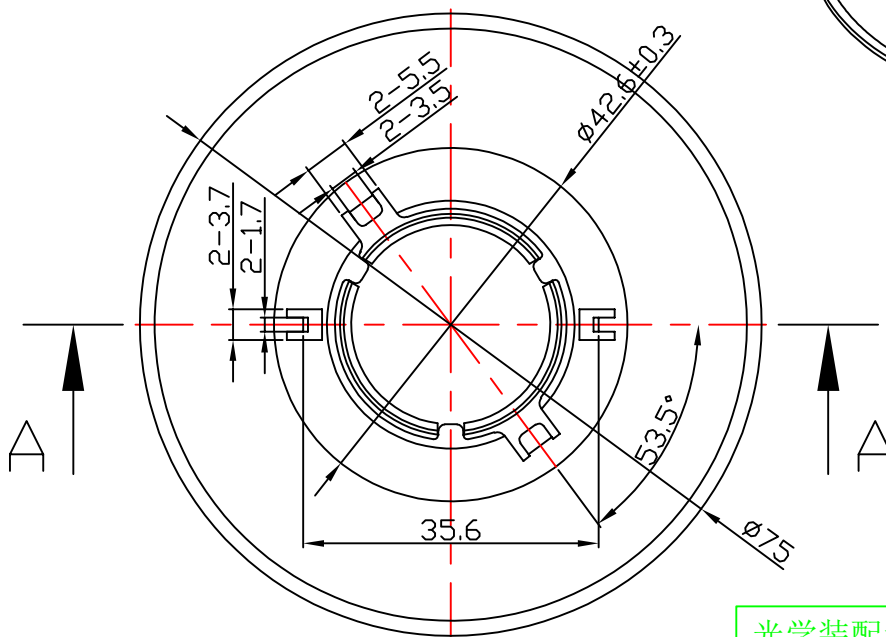
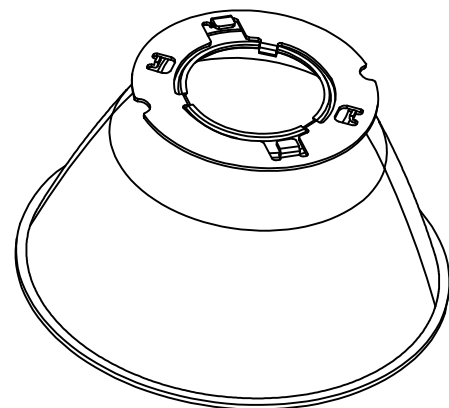
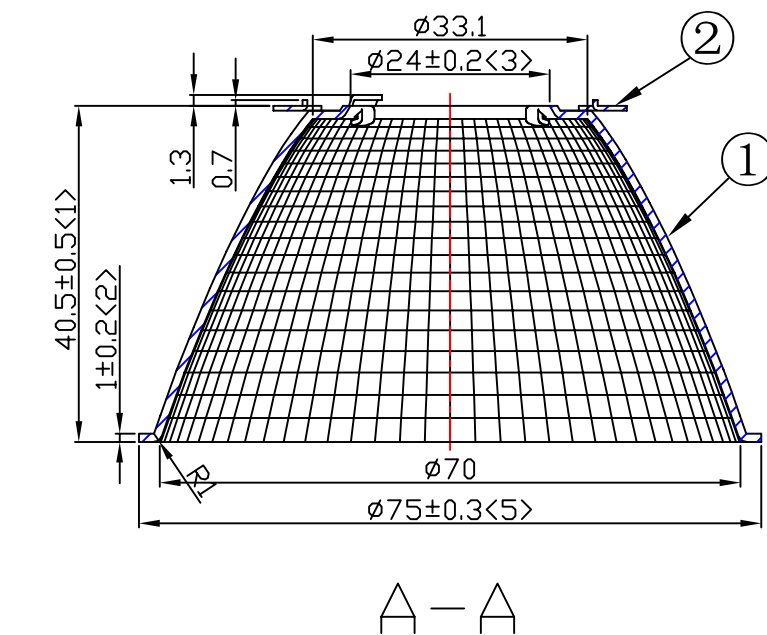

Light Source	CREE CXA1512 LES8.1
PlasticHolder	BJB 47.319.610E
Metal Adaptor	
Design Angle	10° ±3°
Measured Angle	10°
Efficiency	

光学装配示意图

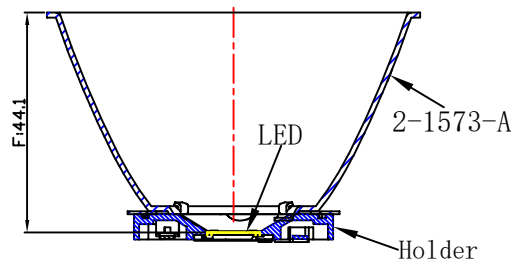

					<p><b>Nata®</b> <b>NATA Lighting Co.,Ltd</b></p>	
Mark	Amended Times	Amended Content		Signature	Amended Date	Customer Item
Control Version	AO	Design Version	KO	Client Version		Customer Code
Designer		Drawing by		Proportion	1:1	Product Number
Technology		Auditor		View		Product Name
Approval		Date	2018.07.01	Page	Total Page	2-1562-M