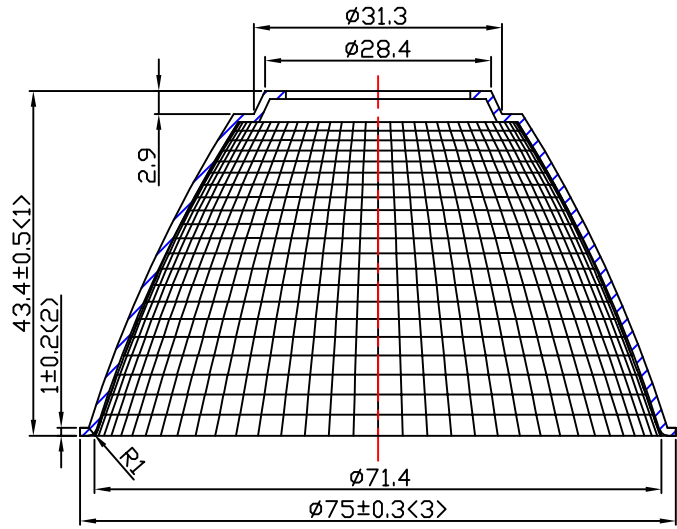
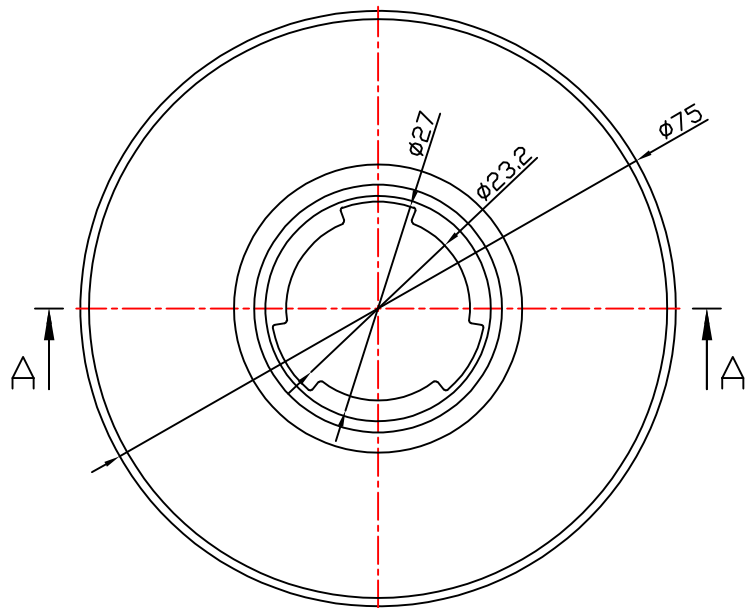

table for unmentioned tolerance in the drawing (unit: mm)			punch angle tolerance in the drawing (unit:degree)		
0-5	5-30	30-120	0-10	10-50	50-120
±0.15	±0.2	±0.5	±1°	±0.5°	±0.3°
120-250	250-400	400-700	120-250	250-360	360 abov
±0.8	±1.5	±2	±0.2°	±0.166°	±0.083



A-A



Light Source	CREE CXAI830
PlasticHolder	99.02.73.18C
Metal Adaptor	92.76.323.0C
Design Angle	15° ±3°
Measured Angle	15.8°
Efficiency	

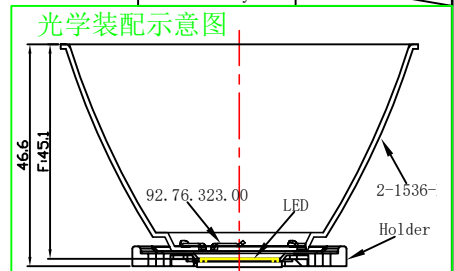

Mark	Amended Times	Amended Content		Signature	Amended Date
Controll Version	AO	Design Version	KO	Client Version	
Designer		Drawing by		Proportion	1:1
Technology		Auditor		View	
Approval		Date	2018 07 11	Page	Total Page

Material:T=1.0
1090AL

Nata[®]
NATA Lighting Co.,Ltd

Customer Item	
Customer Code	NT
Product Number	
Product Name	2-1536-E