

Product bill of material				
Serial number	material name	Masterial number	NO.	Describe
①	2-1850-A	94.02.1850.000	1	Material:T=1.0mm 1090AL
②	020249	97.76.249.00	1	Material:T=0.6mm SUS304

table for unmentioned tolerance in the drawing (unit: mm)			punch angle tolerance in the drawing (unit:degree)		
0-5	5-30	30-120	0-10	10-50	50-120
±0.15	±0.2	±0.5	±1°	±0.5°	±0.3°
120-250	250-400	400-700	120-250	250-360	360 above
±0.8	±1.5	±2	±0.2°	±0.166°	±0.083°

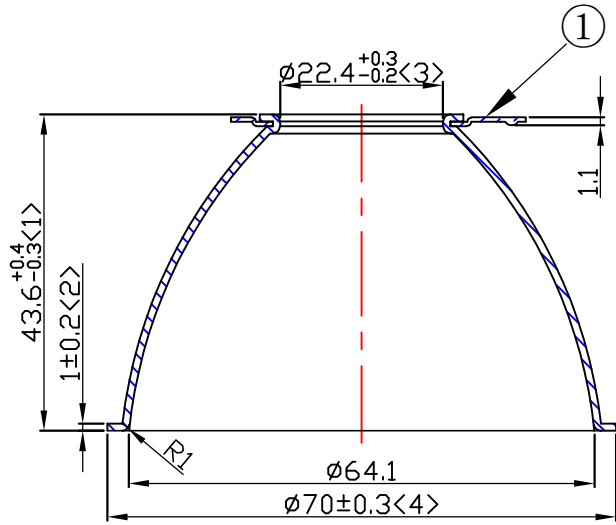

A-A

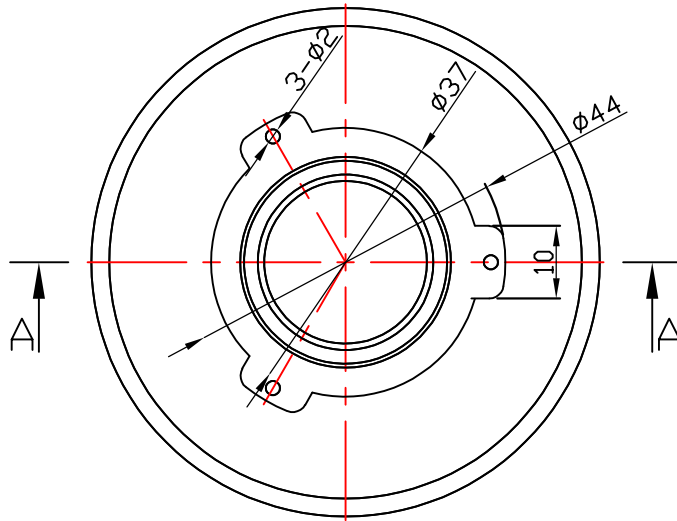

Light Source	XICATO XTM LES 19mm
PlasticHolder	
Metal Adaptor	
Design Angle	35° ±5°
Measured Angle	32.5°
Efficiency	

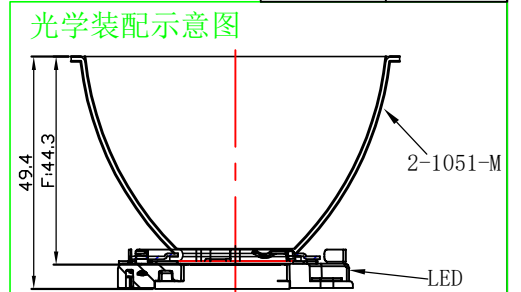

Mark	Amended Times	Amended Content		Signature	Amended Date
Controll Version	B1	Design Version	K0	Client Version	
Designer		Drawing by		Proportion	1:1
Technology		Auditor		View	
Approval		Date	2018.01.10	Page	Total_Page_

Material:T=1.0  
1090AL

**Nata**<sup>®</sup>  
**NATA Lighting Co.,Ltd**

Customer Item	
Customer Code	NT
Product Number	
Product Name	2-1051-M