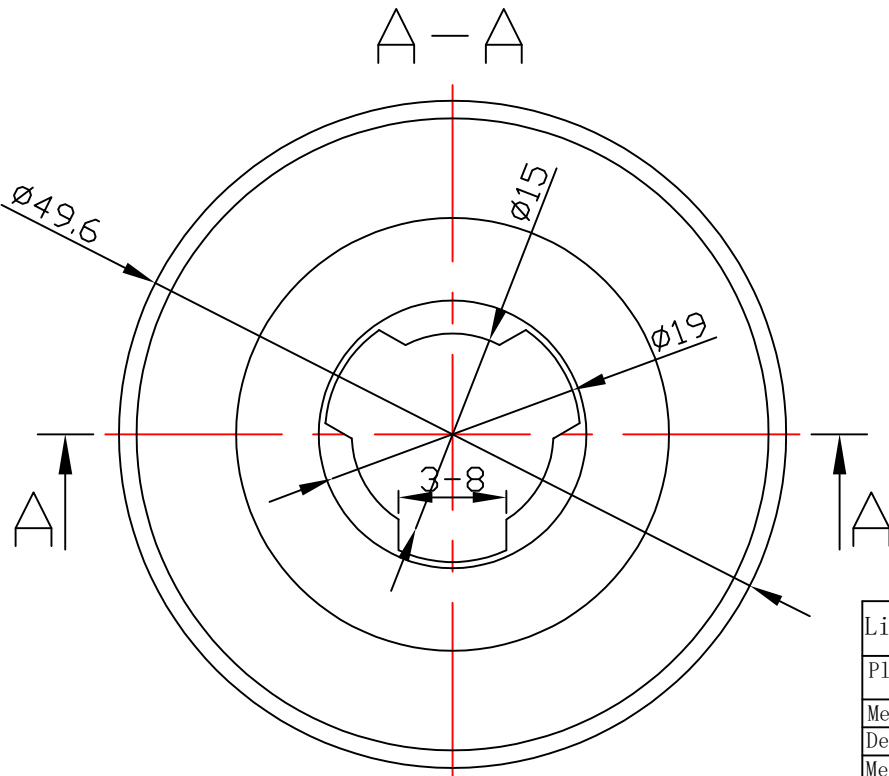
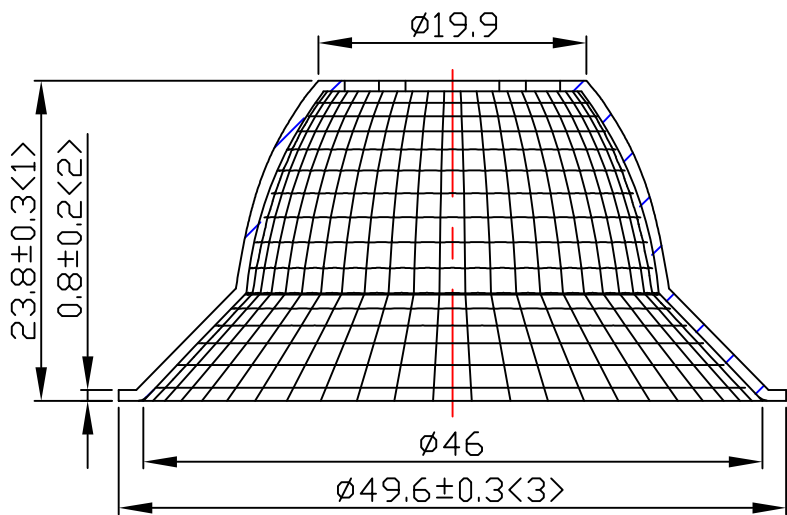
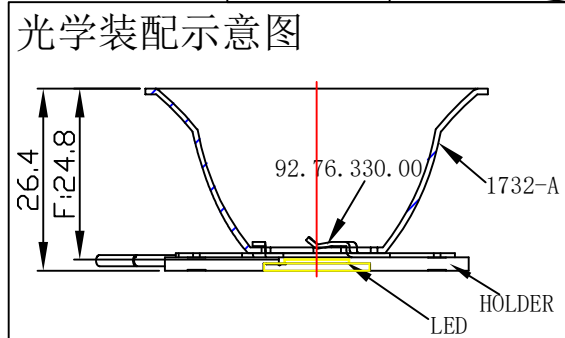

table for unmentioned tolerance in the drawing (unit: mm)			punch angle tolerance in the drawing (unit:degree)		
0-5	5-30	30-120	0-10	10-50	50-120
±0.15	±0.2	±0.5	±1°	±0.5°	±0.3°
120-250	250-400	400-700	120-250	250-360	360 above
±0.8	±1.5	±2	±0.2°	±0.166°	±0.083°



Light Source	BRIDGELUX BXRV-DR-1830 -H-1000-B-13 LES9.3
PlasticHolder	BENDER AND WIRTH HOLDER490
Metal Adaptor	92.76.330.00
Design Angle	60° ±5°
Measured Angle	62.9°
Efficiency	



Mark	Amended Times	Amended Content	Signature	Amended Date
Control Version	A0	Design Version	K0	Client Version
Designer		Drawing by		Proportion 1:1
Technology		Auditor		View
Approval		Date	2017.9.9	Page Total Page

Material:T=0.8 1090AL		Nata [®] NATA Lighting Co.,Ltd	
Customer Item		Customer Code	NT
Product Number		Product Name	1733-A