

Product bill of material				
Serial number	material name	Masterial number	NO.	Describe
①	1710-A	94.01.0710.000	1	Material:T=0.8mm 1090AL
②	020367	97.76.367.00	1	Material:T=0.6mm SUS304

table for unmentioned tolerance in the drawing (unit: mm)			punch angle tolerance in the drawing (unit:degree)		
0-5	5-30	30-120	0-10	10-50	50-120
±0.15	±0.2	±0.5	±1°	±0.5°	±0.3°
120-250	250-400	400-700	120-250	250-360	360 above
±0.8	±1.5	±2	±0.2°	±0.166°	±0.083°

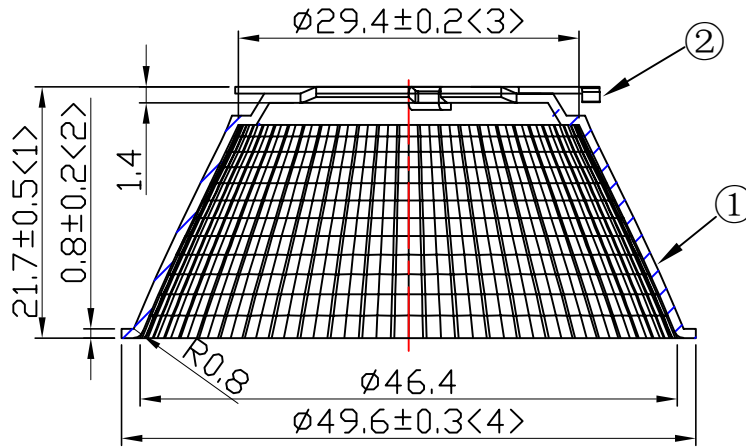

A-A

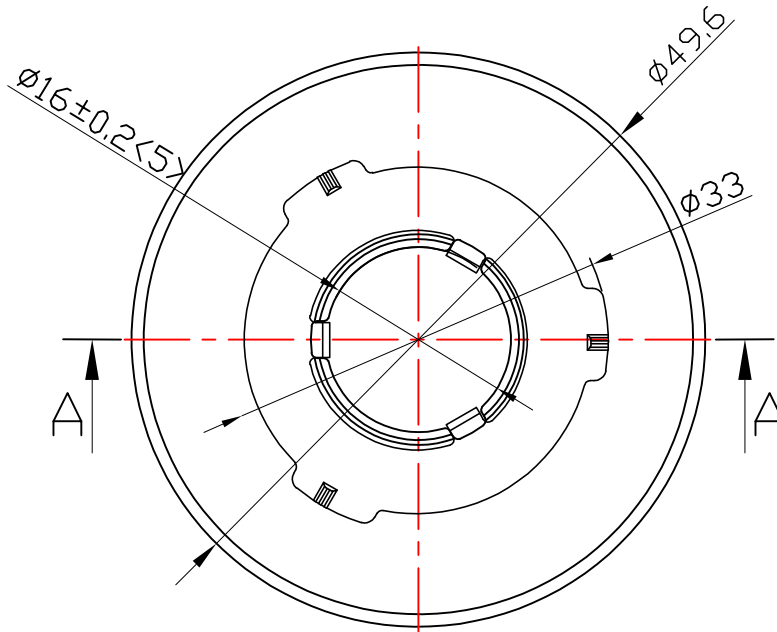

Light Source	CITIZEN CLU026
PlasticHolder	92.70.124.00
Metal Adaptar	
Design Angle	$18^\circ \pm 3^\circ$
Measured Angle	$17.7^\circ$
Efficiency	

光学装配示意图

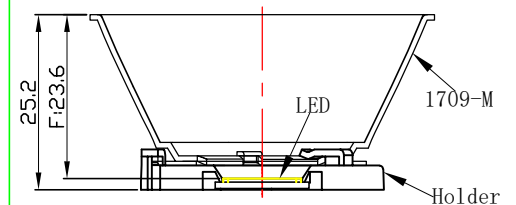

Mark	Amended Times	Amended Content		Signature	Amended Date
Controll Version	AO	Design Version	KO	Client Version	
Designer		Drawing by		Proportion	1:1
Technology		Auditor		View	
Approval		Date	2017.12.29	Page	Total_Page_

Material:T=0.8 1090AL

**Nata**<sup>®</sup>  
**NATA Lighting Co.,Ltd**

Customer Item	
Customer Code	NT
Product Number	
Product Name	1709-M