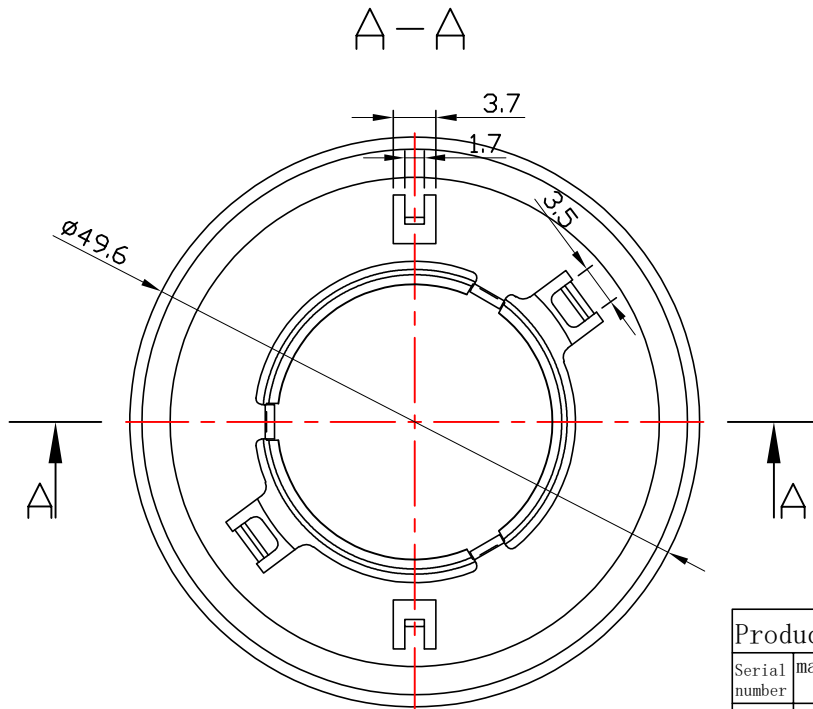
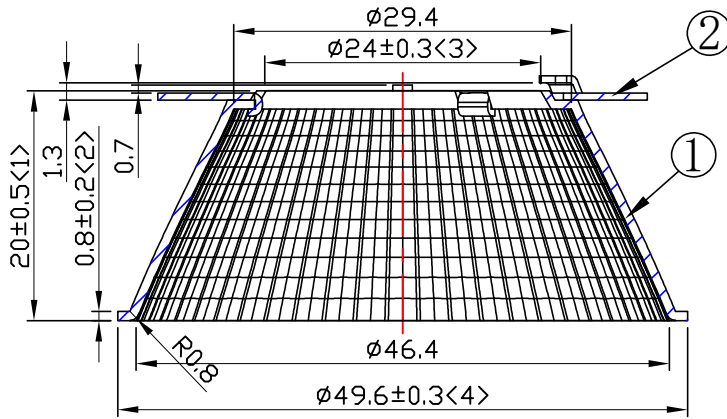

table for unmentioned tolerance in the drawing (unit: mm)			punch angle tolerance in the drawing (unit:degree)		
0-5	5-30	30-120	0-10	10-50	50-120
±0.15	±0.2	±0.5	±1°	±0.5°	±0.3°
120-250	250-400	400-700	120-250	250-360	360 abov
±0.8	±1.5	±2	±0.2°	±0.166°	±0.083°



Light Source	CREE CXA1512
PlasticHolder	BJB 47.319.6105
Metal Adaptor	
Design Angle	$15^\circ \pm 3^\circ$
Measured Angle	15.6°
Efficiency	

Product bill of material					
Serial number	material name	Masterial number	NO.	Pagunation	Describe
①	1636-A	94.01.0636.000	1	1	Material: T=0.8mm 1090Al
②	020359	97.76.359.00	1	2	Material: T=0.6mm SUS30.

光学装配示意图

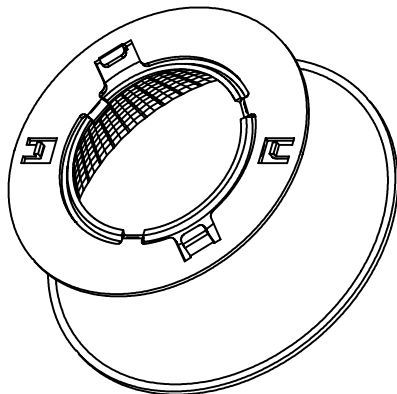
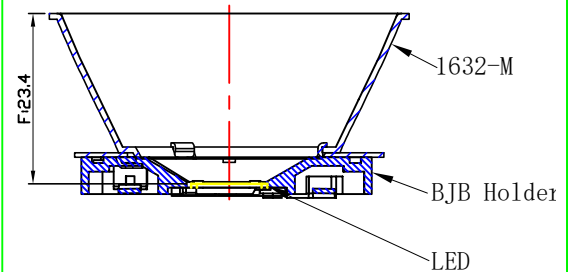

				Material:T=0.8 1090Al		Nata [®] NATA Lighting Co.,Ltd	
Mark	Amended Times	Amended Content		Signature	Amended Date	Customer Item	
Controll Version	AO	Design Version	KO	Client Version		Customer Code	NT
Designer		Drawing by		Proportion	1:1	Product Number	
Technology		Auditor		View		Product Name	1632-M
Approval		Date	2018.07.01	Page	Total_Page_		