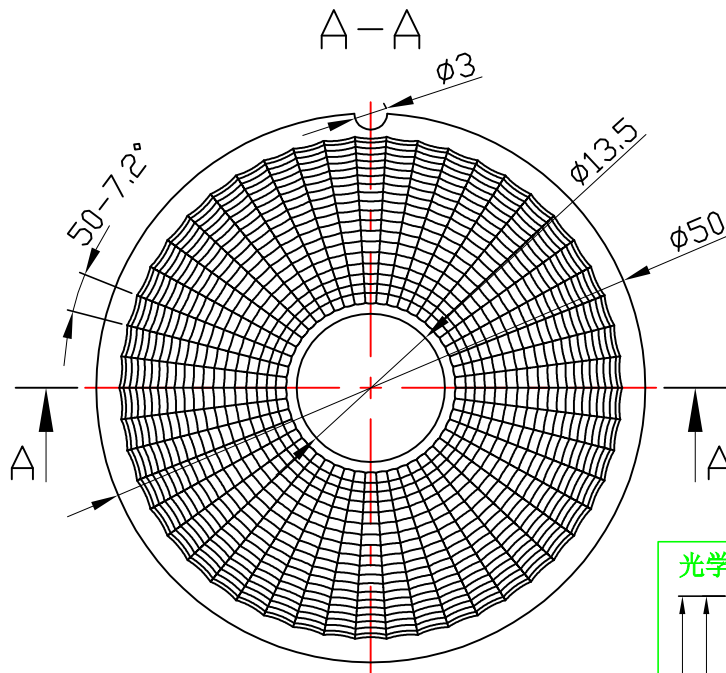
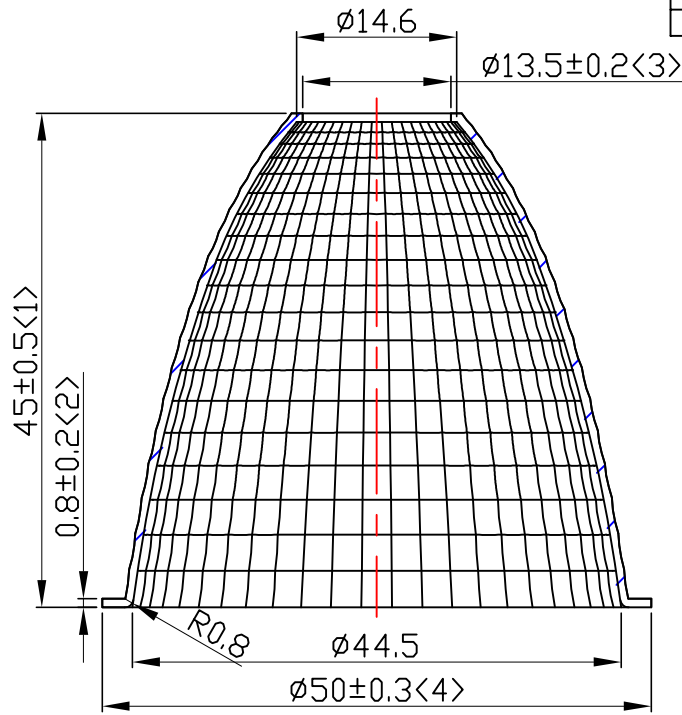
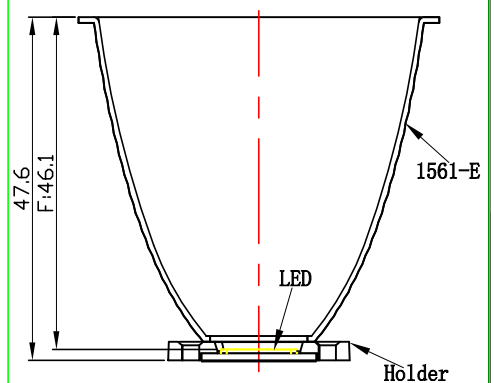

table for unmentioned tolerance in the drawing (unit: mm)			punch angle tolerance in the drawing (unit: degree)		
0-5	5-30	30-120	0-10	10-50	50-120
±0.15	±0.2	±0.5	±1°	±0.5°	±0.3°
120-250	250-400	400-700	120-250	250-360	360 above
±0.8	±1.5	±2	±0.2°	±0.166°	±0.083°



Light Source	CXA1512 LES8.9
PlasticHolder	92.70.046.00
Metal Adaptor	
Design Angle	24° ±3°
Measured Angle	24.4°
Efficiency	

光学装配示意图



Material:T=0.8 1090AL

**Nata**<sup>®</sup>  
**NATA Lighting Co.,Ltd**

Mark	Amended Times	Amended Content		Signature	Amended Date
Control Version	AO	Design Version	KO	Client Version	
Designer		Drawing by		Proportion	1:1
Technology		Auditor		View	
Approval		Date	2018.03.16	Page	Total_Page_

Customer Item	
Customer Code	NT
Product Number	
Product Name	1561-E