

| table for unmentioned tolerance in the drawing (unit: mm) | | | punch angle tolerance in the drawing (unit: degree) | | |
|---|---------|---------|---|---------|-----------|
| 0-5 | 5-30 | 30-120 | 0-10 | 10-50 | 50-120 |
| ±0.15 | ±0.2 | ±0.5 | ±1° | ±0.5° | ±0.3° |
| 120-250 | 250-400 | 400-700 | 120-250 | 250-360 | 360 above |
| ±0.8 | ±1.5 | ±2 | ±0.2° | ±0.166° | ±0.083° |

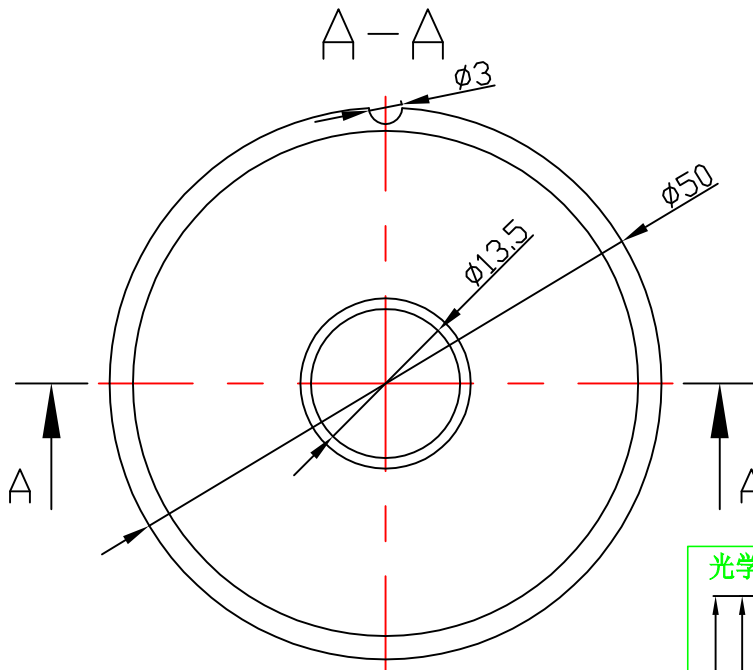

| | |
|----------------|------------------------|
| Light Source | CXA1512 LES8.9 |
| PlasticHolder | 92.70.046.00 |
| Metal Adaptor | |
| Design Angle | $15^\circ \pm 3^\circ$ |
| Measured Angle | 16.1° |
| Efficiency | |

光学装配示意图

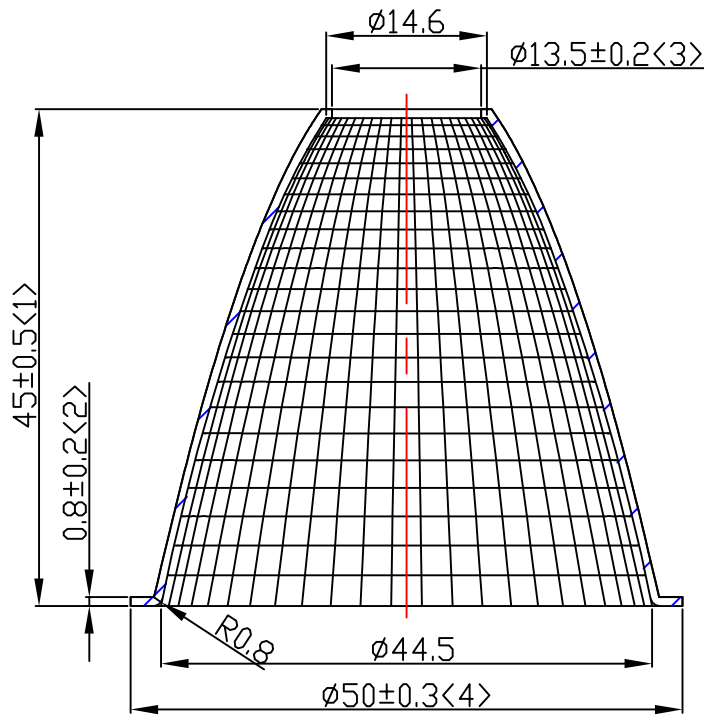
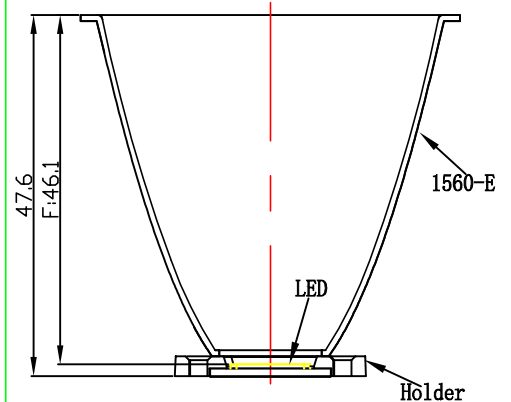

Material:T=0.8 1090AL

Nata[®]
NATA Lighting Co.,Ltd

| | | | | | | | |
|------------------|---------------|-----------------|------------|----------------|--------------|----------------|--------|
| Mark | Amended Times | Amended Content | | Signature | Amended Date | Customer Item | |
| Controll Version | A0 | Design Version | K0 | Client Version | | Customer Code | NT |
| Designer | | Drawing by | | Proportion | 1:1 | Product Number | |
| Technology | | Auditor | | View | | Product Name | 1560-E |
| Approval | | Date | 2018.03.16 | Page | Total Page | | |