

Item NO.	Product Name	Product NO.	QTY	Page	Description
①	EW-D45固定卡环	97.76.748.05	1	4	t=1.0mm 1060AL, Andoizing.
②	1-1212-H		1	2	t=1.2mm 1090AL, Andoizing.
③	EW-45透明片	97.70.363.00	1	3	PC

table for unmentioned tolerance in the drawing (unit: mm)				punch angle tolerance in the drawing (unit: degree)		
> 0-5	> 5-30	> 30-90	> 90-150	0-10	10-50	50-120
±0.15	±0.2	±0.4	±0.5	±1°	±0.5°	±0.3°
> 150-250	> 250-400	> 400-700		120-250	250-360	360 above
±0.8	±1.5	±2		±0.2°	±0.166°	±0.085°

“*” Marked for key control dimensions

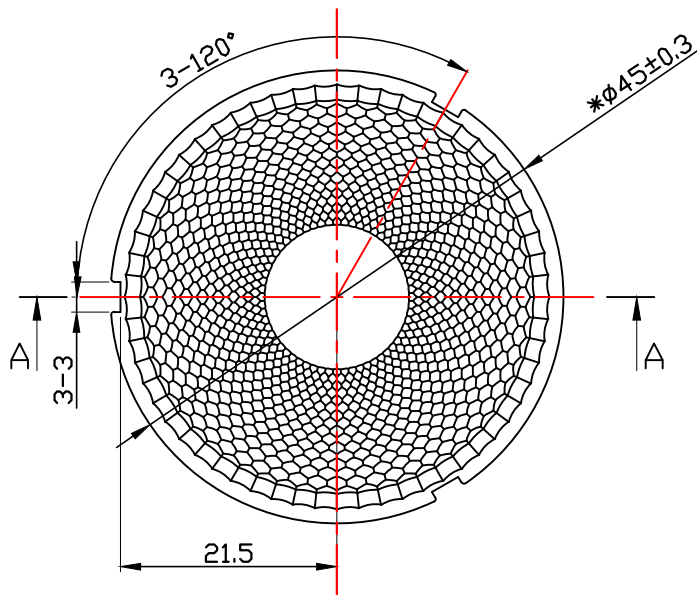
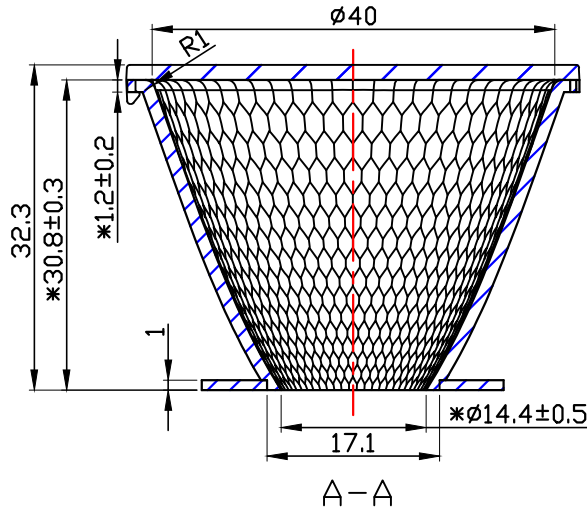

Light Source	CITIZEN CLU028
PlasticHolder	92.70.124.00
Metal Adaptor	
Design Angle	24° ±3°
Measured Angle	
Efficiency	

光学装配示意图

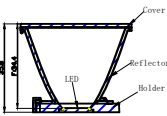

Technical requirements:

1. Material: AL.
2. Surface treatment: Andoizing..
3. Product untolerance reference untolerance table.

				P/N: 91.01.1211.000		版本/REV K2	
				产品名称 Product Name		1-1211-L	
				客户代号 Customer Code		NT	
				客户编号 Customer Item		EW-D45-24D	
标记 Mark	处数 Issued Times	更改内容 Amended Content	签名 Signature	更改日期 Amended Date	工程图 Engineering drawings		
设计 Designer	林工	制图 Drawing by	比例 Proportion	1:1			
工艺 Technology		审核 Auditor	视角 View		图档路径 The path of files		
批准 Approval		日期 Date	页数 Page	共1页 第1页			
					Nata®		