

Product bill of material

Serial number	material name	Masterial number	NO.	Describe
①	1-0953-H	94.01.0953.000	1	Material:T=1.0mm 1090AL
②	D40xD13.9 Metal Adaptor	97.76.774.00	1	Material:T=1.0mm 1060 H22

table for unmentioned tolerance in the drawing (unit: mm)			punch angle tolerance in the drawing (unit:degree)		
0-5	5-30	30-120	0-10	10-50	50-120
±0.15	±0.2	±0.5	±1°	±0.5°	±0.3°
120-250	250-400	400-700	120-250	250-360	360 above
±0.8	±1.5	±2	±0.2°	±0.166°	±0.083°

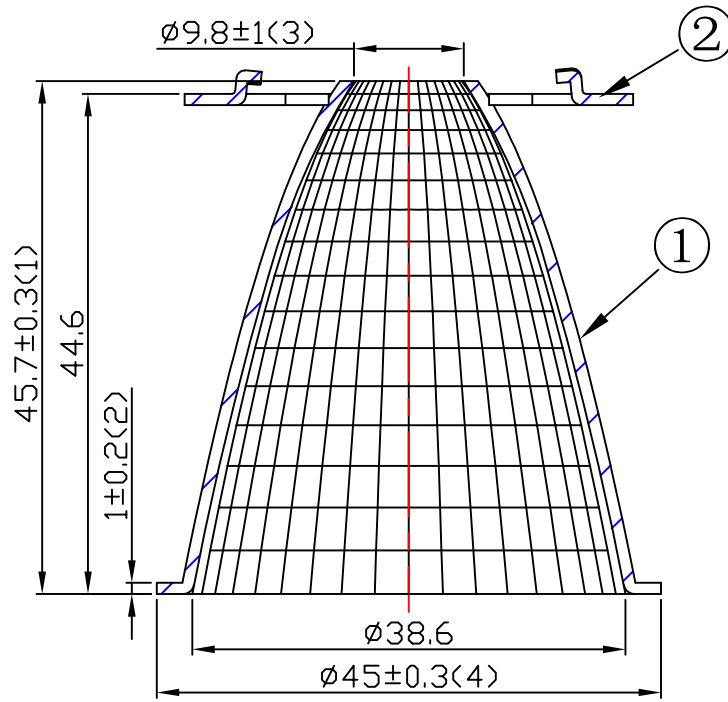

A-A

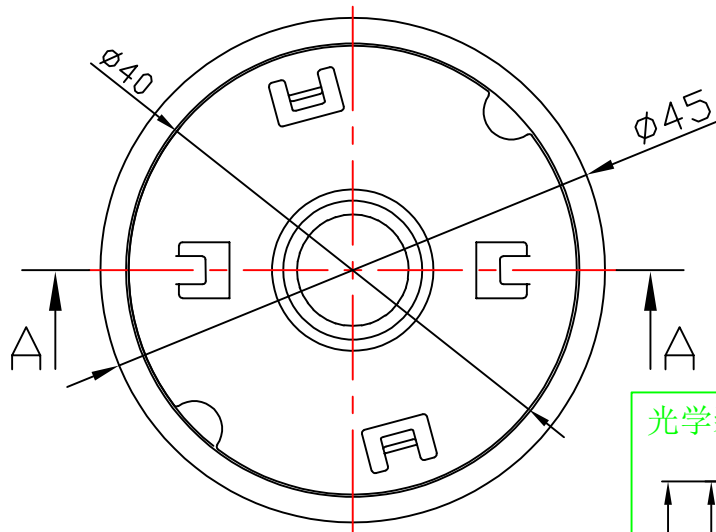

Light Source	CITIZEN CLU28
PlasticHolder	BJB 47.360.1020
Design requiremengt	16° ±3°
Measured result	17.8°

光学装配示意图

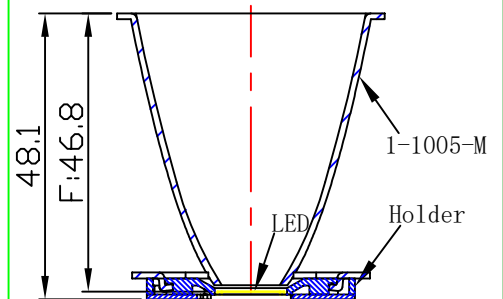

Mark	Amended Times	Amended Content	Signature	Amended Date
Controll Version	AO	Design Version KO	Client Version	
Designer		Drawing by	Proportion	1:1
Technology		Auditor	View	
Approval		Date	Page	Total Page

Nata[®]
NATA Lighting Co.,Ltd

Customer Item	D45深筒G2 BJB系列 16D
Customer Code	NT
Product Number	91.01.1005.000
Product Name	1-1005-M