

Product bill of material				
Serial number	material name	Masterial number	NO.	Describe
①	1-0949-H	94.01.0949.000	1	Material:T=1.2mm 1090AL
②	1-0922-M Metal Adaptar	97.76.747.00	1	Material:T=1.0mm 1060 H22

table for unmentioned tolerance in the drawing (unit: mm)			punch angle tolerance in the drawing (unit:degree)		
0-5	5-30	30-120	0-10	10-50	50-120
±0.15	±0.2	±0.5	±1°	±0.5°	±0.3°
120-250	250-400	400-700	120-250	250-360	360 above
±0.8	±1.5	±2	±0.2°	±0.166°	±0.083°

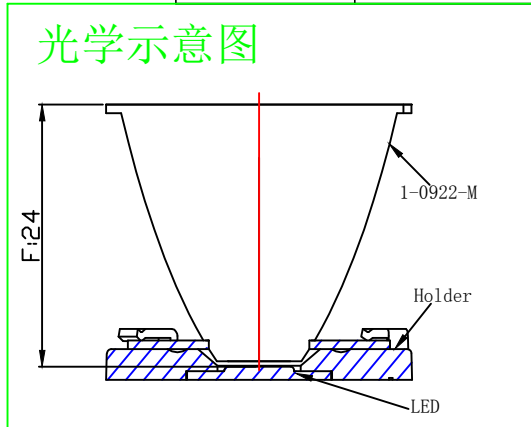
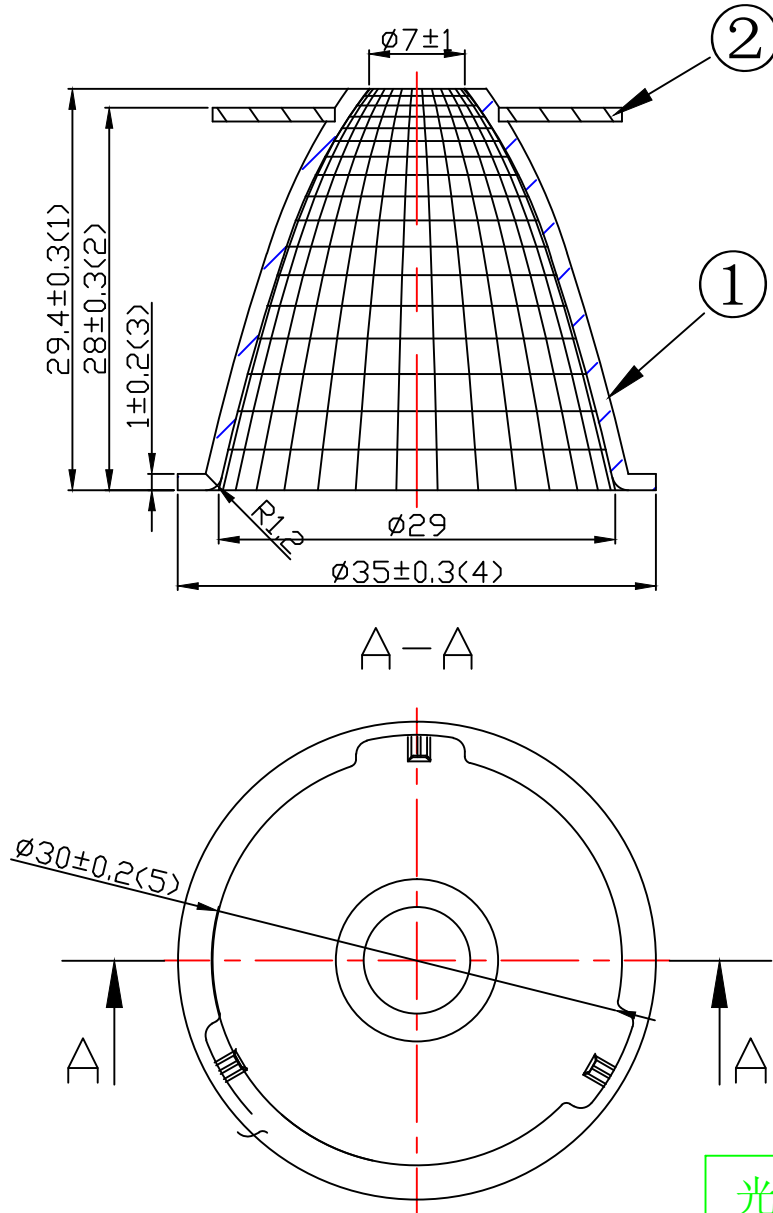

					<b>Nata</b> <sup>®</sup> NATA Lighting Co.,Ltd	
					Customer Item	D35深筒反光杯系列 18°
					Customer Code	NT
					Product Number	91.01.0922.000
					Product Name	1-0922-M
Mark	Amended Times	Amended Content		Signature	Amended Date	
Controll Version	A0	Design Version	K0	Client Version		
Designer	Drawing by		Proportion	1:1		
Technology	Auditor		View			
Approval	Date	2020.01.15	Page	Total Page		