

Dimensions in "*" are critical size
 Undefined tolerances according to GB/T14486-2008-MT6
 (单位: mm)

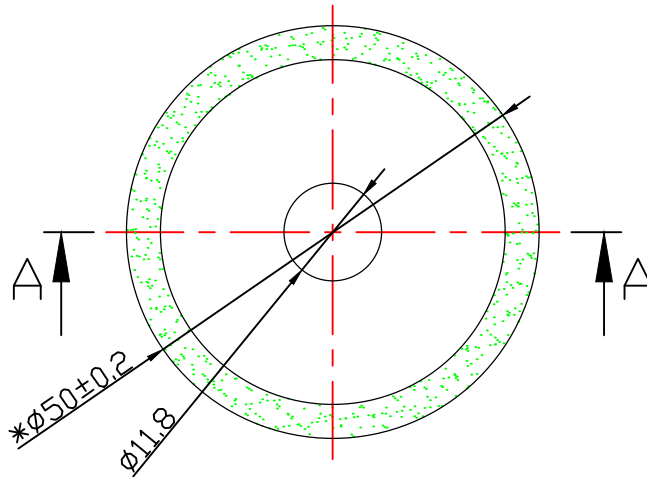
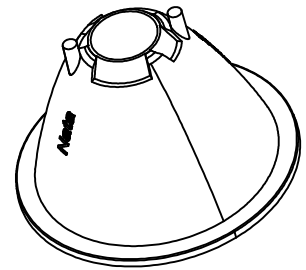
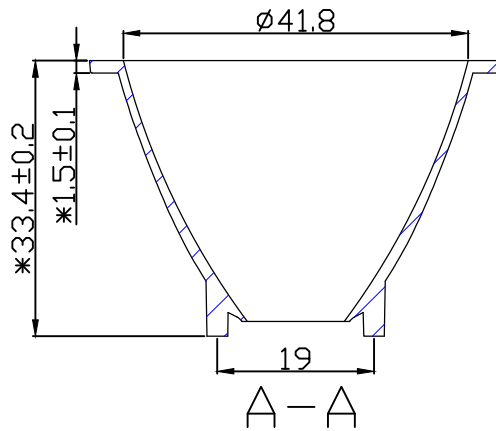
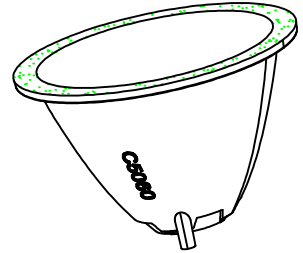
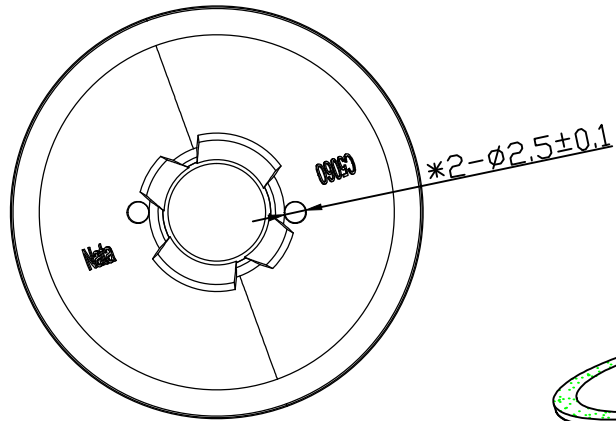

Technical requirements:

1. Material :PC.
2. Surface treatment: transparent + Grind arenaceous.
3. Press 3D for product without fillet and die drawing Angle.
4. No tolerance of the product shall be referred to GB/t14486-2008 no tolerance standard MT5.

								P/N:		版本/REV
								产品名称 Product Name		1-0915-S
								客户代号 Customer Code		NT
								客户编号 Customer Item		
标记 Mark	处数 Amended Times	更改内容 Amended Content		签名 Signature	更改日期 Amended Date	方案图 Engineering drawings 图档路径 The path of file				
设计 Designer		制图 Drawing by		比例 Proportion	1:1					
工艺 Technology		审核 Auditor		视角 View						
批准 Approval		日期 Date	2022. 4. 28	页数 Page	共1页 第1页					
										Nata®