

Product bill of material				
Serial number	material name	Masterial number	NO.	Describe
①	1-0789-A	94.01.0789.000	1	Material:T=0.8 1090AL
②	不锈钢卡环	97.76.367.00	1	Material:T=0.6 SUS304

table for unmentioned tolerance in the drawing (unit: mm)			punch angle tolerance in the drawing (unit:degree)		
0-5	5-30	30-120	0-10	10-50	50-120
±0.15	±0.2	±0.5	±1°	±0.5°	±0.3°
120-250	250-400	400-700	120-250	250-360	360 above
±0.8	±1.5	±2	±0.2°	±0.166°	±0.083°

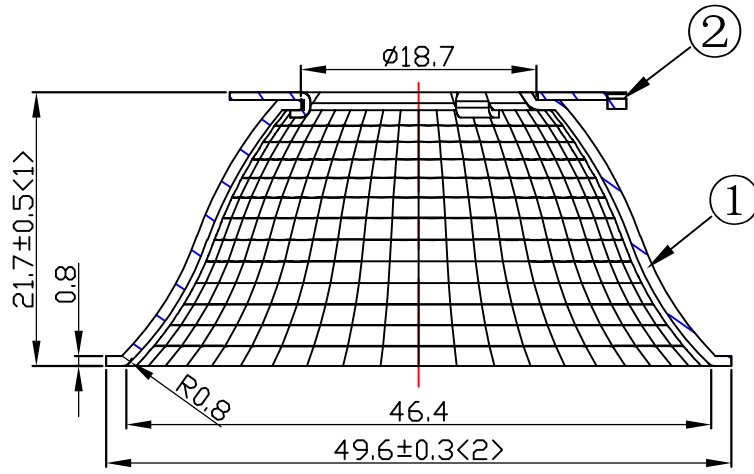

A-A

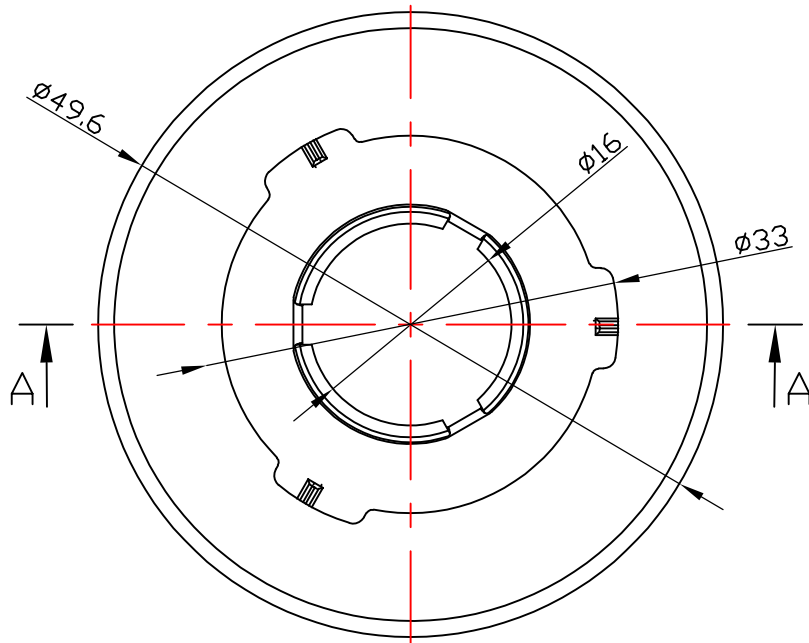

Light Source	CITIZEN CLU026 LES9.8
PlasticHolder	92.70.124.00
Metal Adaptor	
Design Angle	34±5°
Measured Angle	36.4°
Efficiency	

光学装配示意图

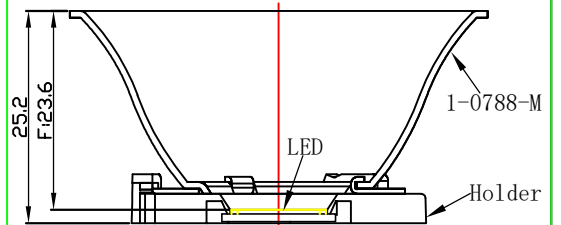

						 NATA Lighting Co.,Ltd	
Mark	Amended Times	Amended Content		Signature	Amended Date	Customer Code	NT
		A0	Design Version KO	Client Version		Product Number	
Designer		Drawing by		Proportion	1:1	Product Name	1-0788-M
Technology		Auditor		View			
Approval		Date	2019.06.18	Page	Total Page		